

TM-227
1st printing

ATARI®
STAR WARS

RETURN OF THE JEDI

Operators Manual

With Illustrated Parts Lists

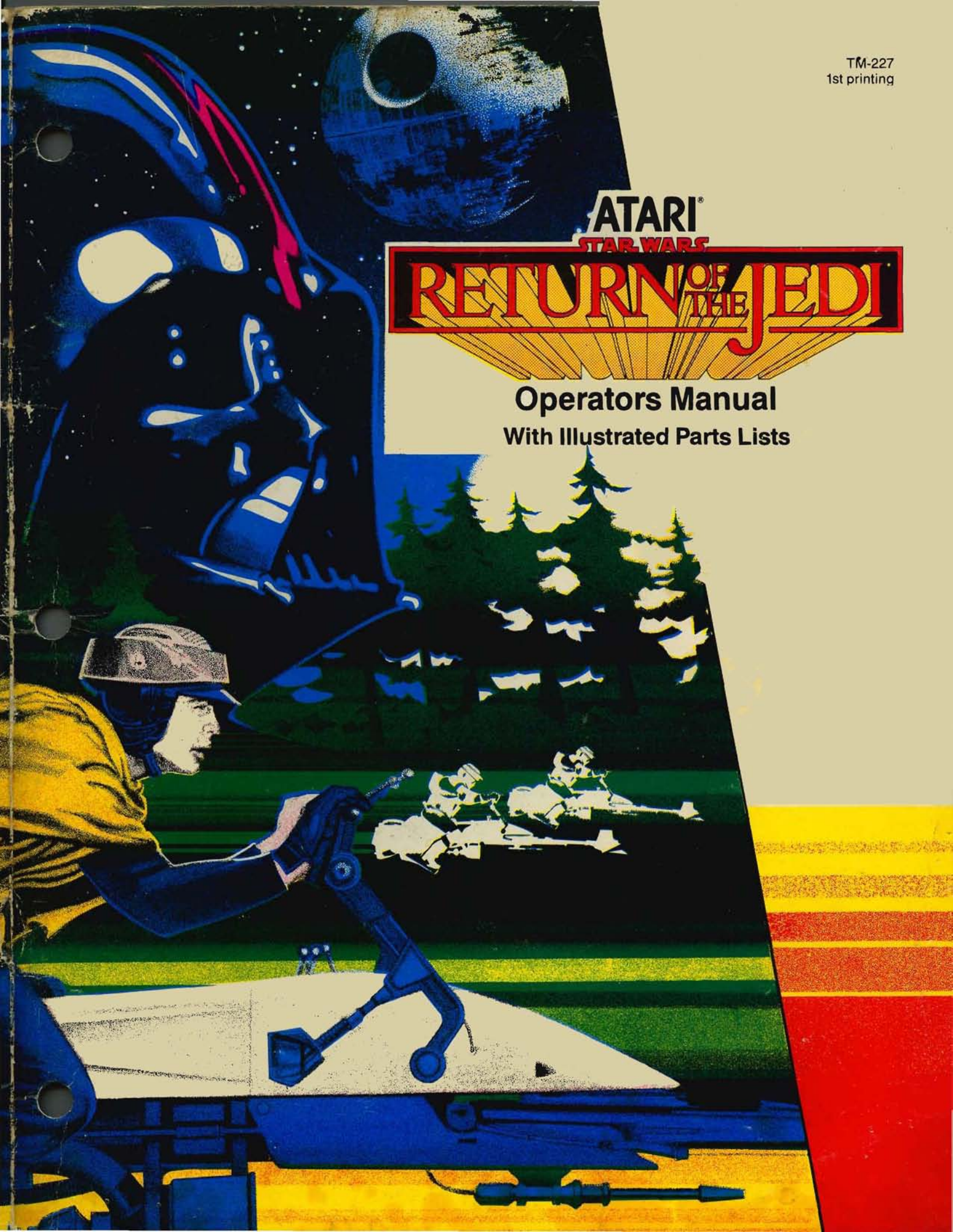

Atari Customer Service

If reading through this manual does not lead to solving a certain maintenance problem, call TELEHELP® at one of these Atari Customer Service offices:

UNITED STATES

Parts and Service

Atari, Inc.
California Customer Service Office
737 Sycamore
P.O. Box 906
Milpitas, CA 95035
Telex 17-2976
(Monday–Friday, 7:30–4:00 pm Pacific Time)

 **(408) 943-1120**

EUROPE

Parts and Service

Atari Ireland Limited
European Customer Service Office
Tipperary Town, Ireland
Telex 28165
(Monday–Friday, 9:00–6:00 pm GMT)

 **062-52155**

ATARI[®]
STAR WARS
RETURN OF THE JEDI

Operators Manual

With Illustrated Parts Lists

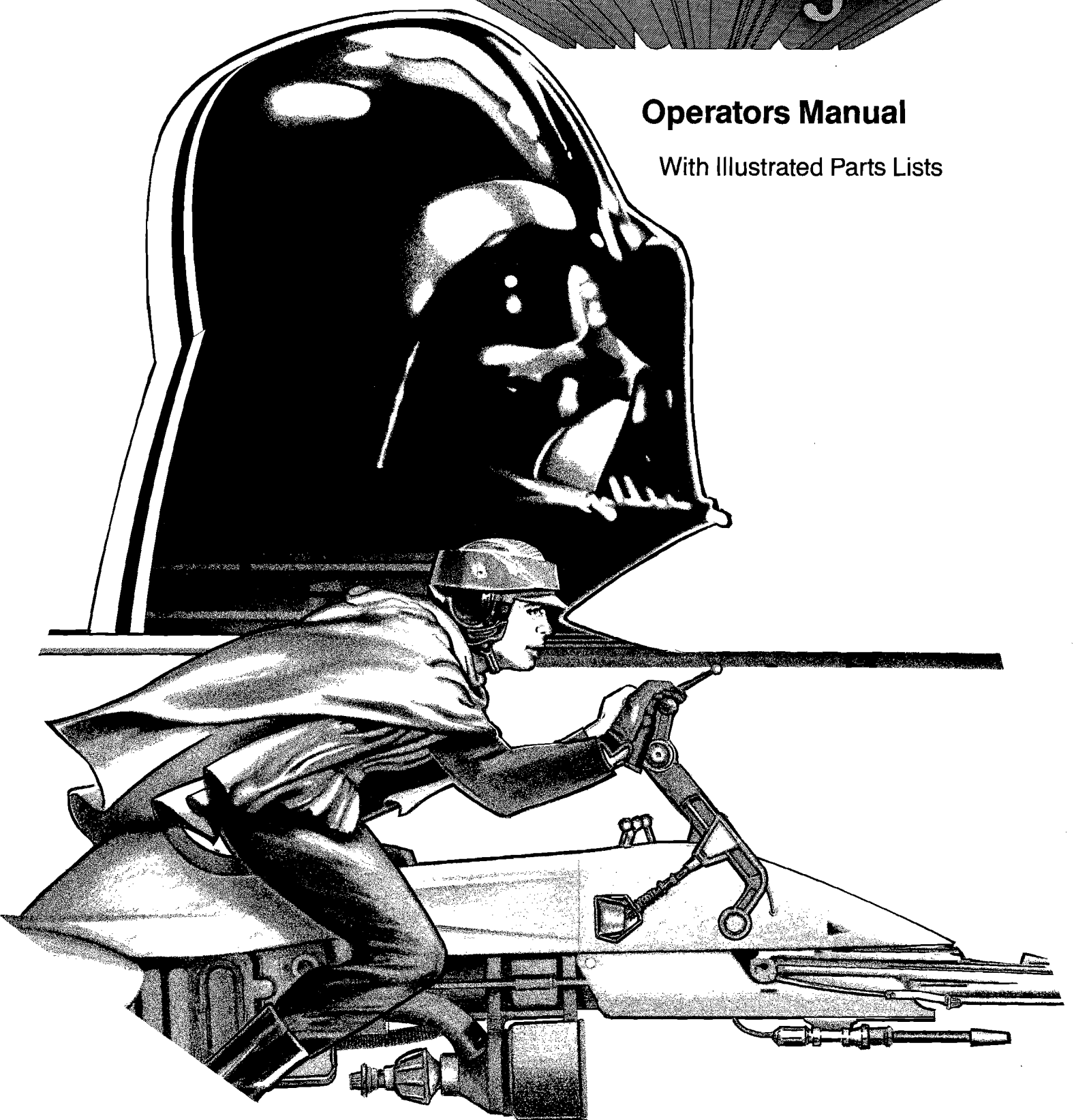

© 1984 by Atari, Inc.

All rights reserved.

No part of this publication may be reproduced by any mechanical, photographic, or electronic process, or in the form of a phonographic recording, nor may it be stored in a retrieval system, transmitted, or otherwise copied for public or private use, without permission from the publisher.

The game play, all graphic designs, this technical manual, its accompanying schematic diagrams, and the display manual are protected by the U.S. Copyright Act of 1976.

This Act provides for increased penalties for violating federal copyright laws. Courts *can impound* infringing articles while legal action is pending. If infringers are convicted, courts can *order destruction* of the infringing articles.

In addition, the Act provides for payment of statutory damages of up to \$250,000 in certain cases. Infringers may also have to pay costs and attorneys' fees and face an imprisonment of up to five years.

Atari will aggressively enforce its copyrights against any infringers. *We will use all legal means* to immediately halt any manufacture, distribution, or operation of a copy of video games made by us. Anyone who purchases such copies risks forfeiting such a game.

Published by: Atari, Inc.
1501 McCarthy Blvd.
P.O. Box 906
Milpitas, California 95035

Printed in the U.S.A.

8N

Notice Regarding Non-Atari Parts

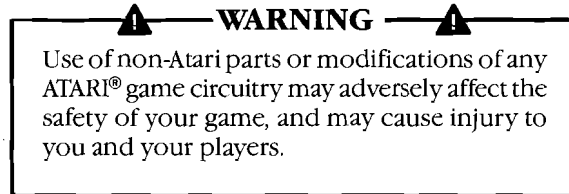

You may void the game warranty (printed on the inside back cover of this manual) if you do any of the following:

- Substitute non-Atari parts in the game.
- Modify or alter any circuits in the game by using kits or parts *not* supplied by Atari.

NOTE

This equipment generates, uses, and can radiate radio frequency energy and if not installed and used in accordance with the instruction manual, may cause interference to radio communications. It has been tested and found to comply with the limits for a Class A computing device pursuant to Subpart J of Part 15 of Federal Communications Commission (FCC) Rules, which are designed to provide reasonable protection against such interference when operated in a commercial environment. Operation of this equipment in a residential area or modification to this equipment is likely to cause interference in which case the user, at his own expense, will be required to take whatever measures may be required to correct the interference. If you suspect interference from an ATARI® game at your location, check the following:

- All green ground wires in the game are properly connected as shown in the game wiring diagram.
- The power cord is properly plugged into a grounded three-wire outlet.
- The game printed-circuit boards (PCB) are properly installed within the Electromagnetic Interference (EMI) cage.
- The EMI Shield PCB is properly installed and connected in series with the game PCB harness.
- All filter capacitors required on the EMI Shield PCB are properly soldered in place.

If you are still unable to solve the interference problem, please contact Atari Customer Service. See the inside front cover of this manual for service in your area.

Table of Contents

1	Set Up	
	How to Use This Manual	1-1
	Game Overview	1-3
	Inspecting the Game	1-3
	Voltage-Plug Selection and Fuses	1-3
	Switch Information	1-4
	Option Settings	1-4
	Game Play	1-5
	High-Score Mode	1-6
	Self-Test Mode	1-6
	Glossary of Terms	GL1
2	Self-Test	
	Self-Test Displays	2-2
3	Maintenance	
	Preventive Maintenance	3-2
	Preventive-Maintenance Intervals	3-2
	Removing the Control Panel	3-2
	Lubricating the Flight Control	3-2
	Tightening the Flight-Control Hardware	3-4
	Cleaning the Coin Mechanism	3-4
	Cleaning the Cabinet and Display Shield	3-4
	Corrective Maintenance	3-5
	Flight Control	3-5
	Aligning the Flight-Control Potentiometers	3-9
	Calibrating the Flight Control	3-9
	Removing the Display Shield and Bezel	3-10
	Removing the Display	3-10
	Removing the Light-Panel Assembly	3-12
	Removing the Speakers	3-12
4	Troubleshooting	
	Troubleshooting Aids	4-2
	Troubleshooting Procedures	4-2
	Troubleshooting Techniques	4-2
	Soldering Techniques	4-2
	Troubleshooting Static-Sensitive Devices	4-3

5 Illustrated Parts Lists

Figure 5-1	Cabinet-Mounted Assemblies	5-2
Figure 5-2	Control Panel Assembly	5-6
Figure 5-3	Flight-Control Assembly	5-7
Figure 5-4	Fluorescent Tube Assembly	5-10
Figure 5-5	Power Supply Assembly	5-12
Figure 5-6	Utility Panel Assembly	5-14
Figure 5-7	Coin Controls, Inc. Coin Door Assembly	5-15
Figure 5-8	Coin Acceptors, Inc. Coin Door Assembly	5-18
Figure 5-9	Printed-Circuit Board Mounting Hardware	5-21
Figure 5-10	Main Printed-Circuit Board Assembly	5-22
Figure 5-11	PIXI II Printed-Circuit Board Assembly	5-33
Figure 5-12	Regulator/Audio II Printed-Circuit Board Assembly	5-34

List of Illustrations

Figure 1-1	Game Overview	1-2
Figure 1-2	Voltage-Plug Selection and Fuse Locations	1-4
Figure 2-1	RAM/ROM Test—Passes	2-2
Figure 2-2	RAM/ROM Test—Fails	2-2
Figure 2-3	Statistics	2-3
Figure 2-4	Game Options	2-3
Figure 2-5	Sound Processor Test	2-3
Figure 2-6	Control Test	2-4
Figure 2-7	Color Bars	2-4
Figure 2-8	Grid Pattern	2-5
Figure 3-1	Removing the Control Panel and Flight Control	3-2
Figure 3-2	Flight-Control Handle Assembly	3-3
Figure 3-3	Flight-Control Steering Assembly	3-4
Figure 3-4	Removing the Video Display and Light-Panel Assembly	3-11
Figure 4-1	Removing IC (Cut Pin Method)	4-3
Figure 4-2	Removing IC Pins	4-3
Figure 4-3	Removing Solder from Plated-Through Holes	4-4
Figure 4-4	Removing Solder from Lead Connection Pads	4-4

List of Tables

Table 1-1	Installation Specifications	1-3
Table 1-2	Coin and Credit Settings	1-5
Table 1-3	Game Option Settings	1-5
Table 3-1	Recommended Preventive-Maintenance Intervals	3-2

Safety Summary

The following safety precautions apply to all game operators and service personnel. Specific warnings and cautions will be found throughout this manual where they apply.

⚠ WARNING ⚠

Properly Ground the Game. Players may receive an electrical shock if this game is not properly grounded! To avoid electrical shock, do not plug in the game until it has been inspected and properly grounded. This game should only be plugged into a grounded 3-wire outlet. If you have only a 2-wire outlet, we recommend you hire a licensed electrician to install a grounded outlet. Players may receive an electrical shock if the control panel is not properly grounded! After servicing any parts on the control panel, check that the grounding clip is firmly secured to the metal tab on the inside of the control panel. Only then should you lock up the game.

AC Power Connection. Before connecting the game to the AC power source, verify that the proper voltage-selection plug is installed on the game's power supply.

Disconnect Power During Repairs. To avoid electrical shock, disconnect the game from the AC power source before removing or repairing any part of the game. When removing or repairing the video display, extra precautions must be taken to avoid electrical shock because high voltages may exist within the display circuitry and cathode-ray tube (CRT) even after power has been disconnected. Do not touch internal parts of the display with your hands or with metal objects! Always discharge the high voltage from the CRT before servicing this area of the game. To discharge the CRT: Attach one end of a large, well-insulated, 18-gauge jumper wire to ground. Momentarily touch the free end of the grounded jumper to the CRT anode by sliding it under the anode cap. Wait two minutes and discharge the anode again.

Use Only ATARI Parts. To maintain the safety integrity of your ATARI game, do not use non-Atari parts when repairing the game. Use of non-Atari parts or other modifications to the game circuitry may adversely affect the safety of your game, and injure you or your players.

Handle Fluorescent Tube and CRT With Care. If you drop a fluorescent tube or CRT and it breaks, it may implode! Shattered glass can fly six feet or more from the implosion.

Use the Proper Fuses. To avoid electrical shock, use replacement fuses which are specified in the parts list for this game. Replacement fuses must match those replaced in fuse type, voltage rating, and current rating. In addition, the fuse cover must be in place during game operation.

CAUTION

Properly Attach All Connectors. Make sure that the connectors on each printed-circuit board (PCB) are properly plugged in. Note that they are keyed to fit only one way. If they do not slip on easily, do not force them. A reversed connector may damage your game and void the warranty.

Ensure the Proper AC Line Frequency. Video games manufactured for operation on 60 Hz line power (i.e., United States) must not be operated in countries with 50 Hz line power (i.e., Europe). The fluorescent light ballast transformer will overheat, causing a potential fire hazard if 60 Hz games are operated on power lines using 50 Hz. Check the product identification label of your game for the line frequency required.

Set Up

How to Use This Manual

This manual, written for game operators and service technicians, describes how to set up, maintain, and service your new ATARI game.

Chapter 1 provides a game overview, game specifications, inspection procedures, switch information, option information, and a description of game play.

Chapter 2 provides self-test procedures.

Chapter 3 provides maintenance and repair procedures.

Chapter 4 provides troubleshooting procedures.

Chapter 5 provides illustrated parts lists.

Schematic diagrams of the game circuitry are included in the SP-227 supplement to this manual.

⚠ WARNING ⚠

To avoid electrical shock, do not plug in the game until it has been properly inspected and set up for the line voltage in your area.

This game should only be connected to a grounded 3-wire outlet. If you have only a 2-wire outlet, we recommend you hire a licensed electrician to install a grounded outlet. Players may receive an electrical shock if this game is not properly grounded.

Do not touch internal parts of the display with your hands or with metal objects!

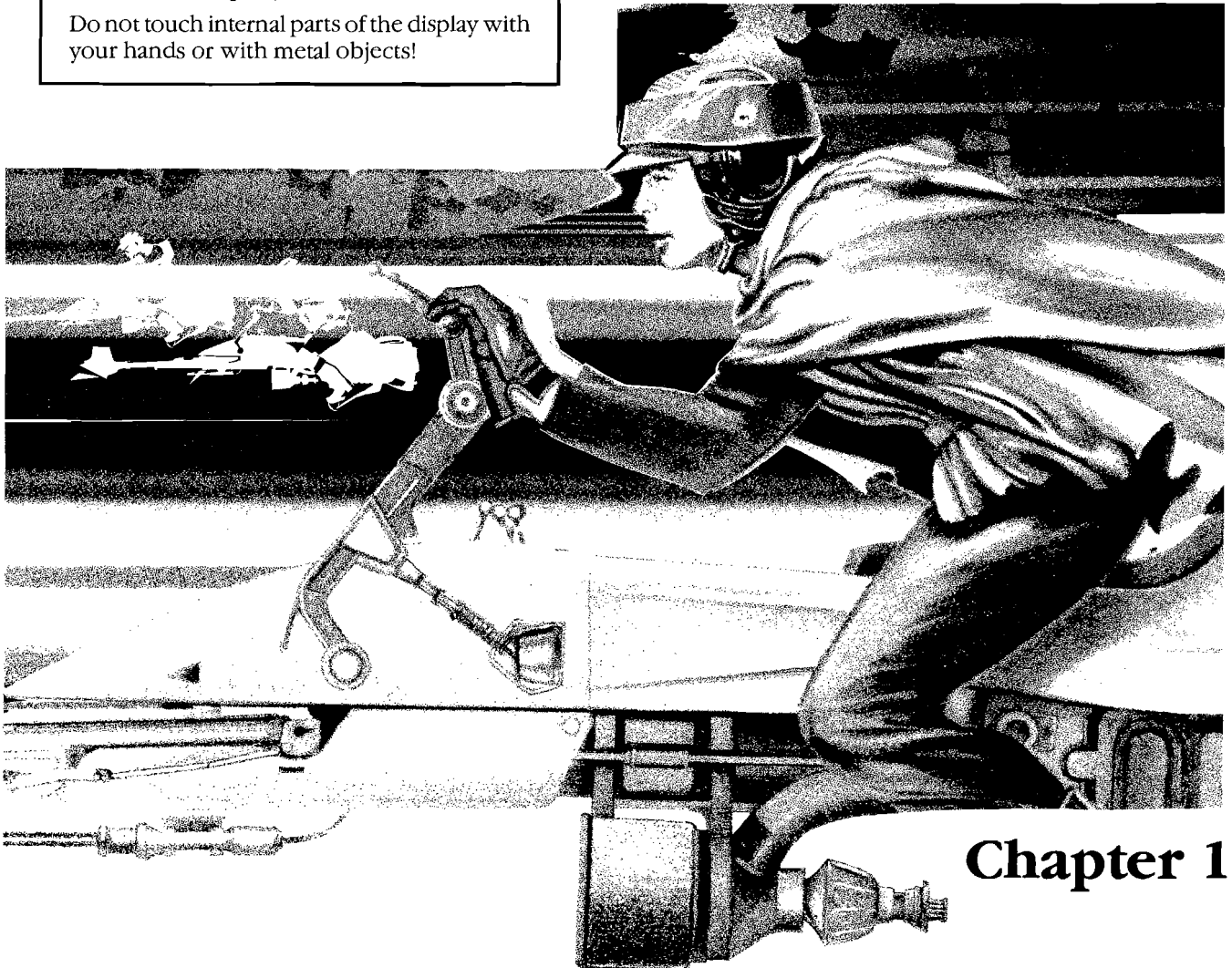

Chapter 1

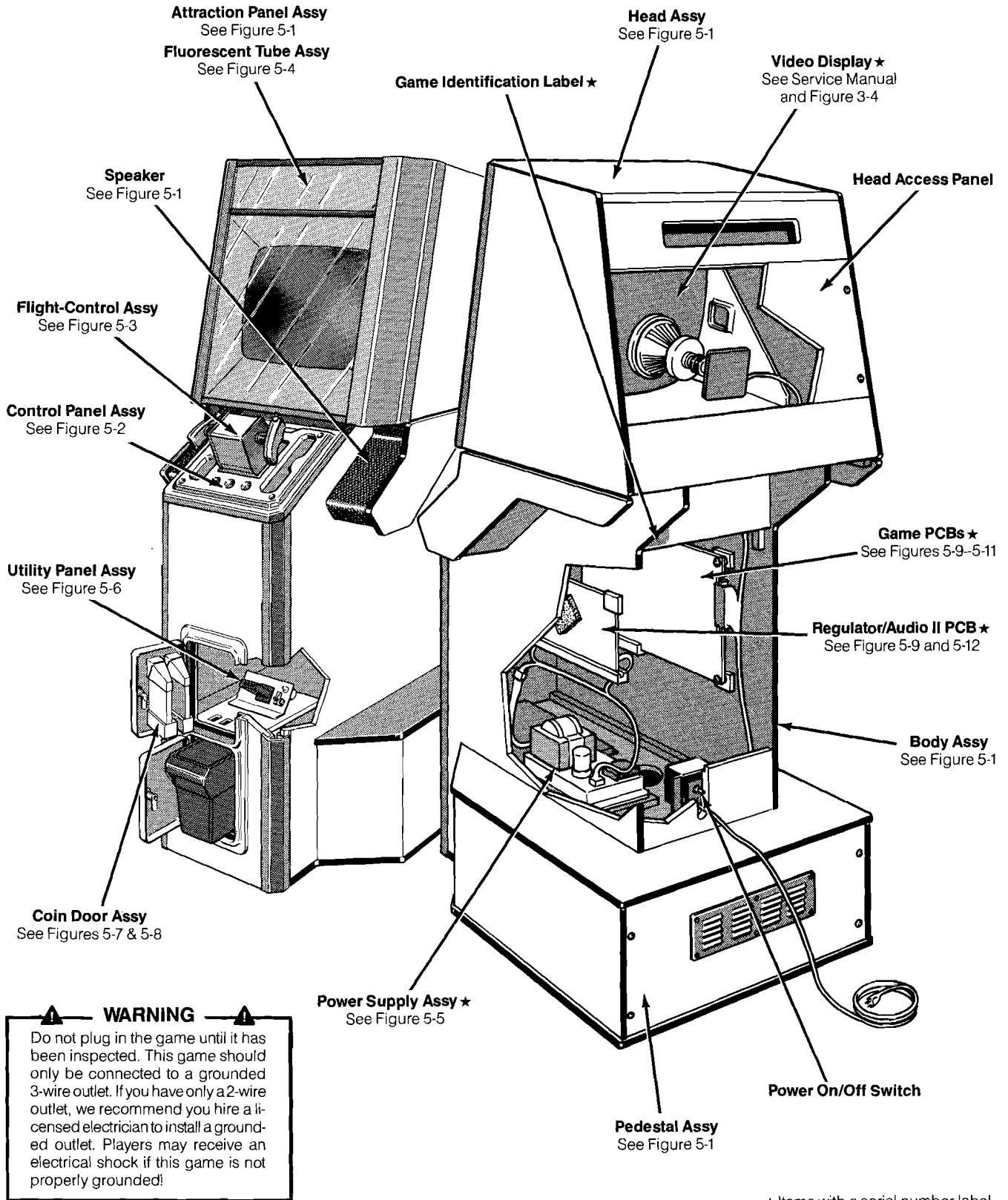

Figure 1-1 Game Overview

Game Overview

RETURN OF THE JEDI* is the latest coin-operated adventure game from Atari. RETURN OF THE JEDI is a one-player game that features the thrills and excitement of the continuing STAR WARS* saga.

The new *split-wave* game-play feature cuts back and forth between two simultaneously occurring action scenes, just like the movie. For an overview of the cabinet and main assemblies see Figure 1-1.

Inspecting the Game

WARNING

Do not plug in the game until you have completed steps 1 through 3!

Please inspect your game carefully to ensure that it was delivered to you in good condition. Table 1-1 lists space, power, and other environmental requirements for this game.

1. Examine the exterior of the game cabinet for dents, chips, or broken parts.
2. Remove the screws from the body access panel. Unlock and open this panel and the coin door. Inspect the interior of the game as follows:
 - a. Ensure that all plug-in connectors (on the game harnesses) are firmly plugged in. Replug any connectors found unplugged. Do not force connectors together. The connectors are keyed so they only fit in the proper orientation. *A reversed edge connector may damage a printed-circuit board (PCB) and will void your warranty.*
 - b. Ensure that all plug-in integrated circuits on the game PCB are firmly plugged into their sockets.
 - c. Remove the power cord from the clamp at the back of the cabinet. Inspect the power cord for any cuts or dents in the insulation. Repair or replace it, if required.
 - d. Inspect the power supply. Make sure the harness is plugged in correctly and that the fuse-block cover is mounted in place. Check that the green ground wire is connected.
 - e. Inspect other major subassemblies, such as the control panel, video display, PCBs, speakers, and the fluorescent tube. Make sure they are mounted securely and that the green ground wires are connected.

WARNING

Replace fuses only with an identical type fuse with the same electrical rating.

3. Check for proper line voltage and make sure you are using the correct voltage-selection plug (see *Voltage-Plug Selection and Fuses*).
4. Calibrate the flight control as follows:
 - a. Move the flight control to the extreme left and right, then up and down. Repeat this procedure three or four times. During this action, the game circuitry monitors the control and calibrates the potentiometers.
 - b. Players also calibrate the control during normal game play, but this may take a few seconds to be optimized.
 - c. If the player-controlled object fails to return to center when the flight control is released, refer to Chapter 2 Self Test and the *Vertical Potentiometer* and *Horizontal Potentiometer* subsections in Chapter 3.

Table 1-1 Installation Specifications

Characteristic	Specification
Power Consumption	265 VA; 180 W RMS
Temperature	+5° to +38° C (+37° to +100° F)
Humidity	Not to exceed 95% relative
Line Voltage	100–132 VAC (or 200–264 VAC)
Width	25.2 in. (64.1 cm)
Depth	36 in. (91.4 cm)
Height	68.5 in. (174 cm)
Weight	320 lbs. (145 kg)

Voltage-Plug Selection and Fuses

The power supply in your game contains six fuses. When you replace a fuse, use the identical type fuse with the same electrical rating (see Figure 1-2).

The power supply operates on the line voltage of many countries. The power supply is sold with either one, two, or three voltage-selection plugs. Plug voltages and wire colors are 100 VAC (violet), 120 VAC (yellow), 220 VAC (blue), and 240 VAC (brown).

See Figure 1-2 for placement of the voltage-selection plugs. Before plugging in your game, check your line voltage. Next, check the wire color on the voltage-selection plug. Make sure the voltage-selection plug is correct for the line voltage in your location.

Now plug the game into a *grounded* three-wire outlet and set the power on/off switch to the *ON* position.

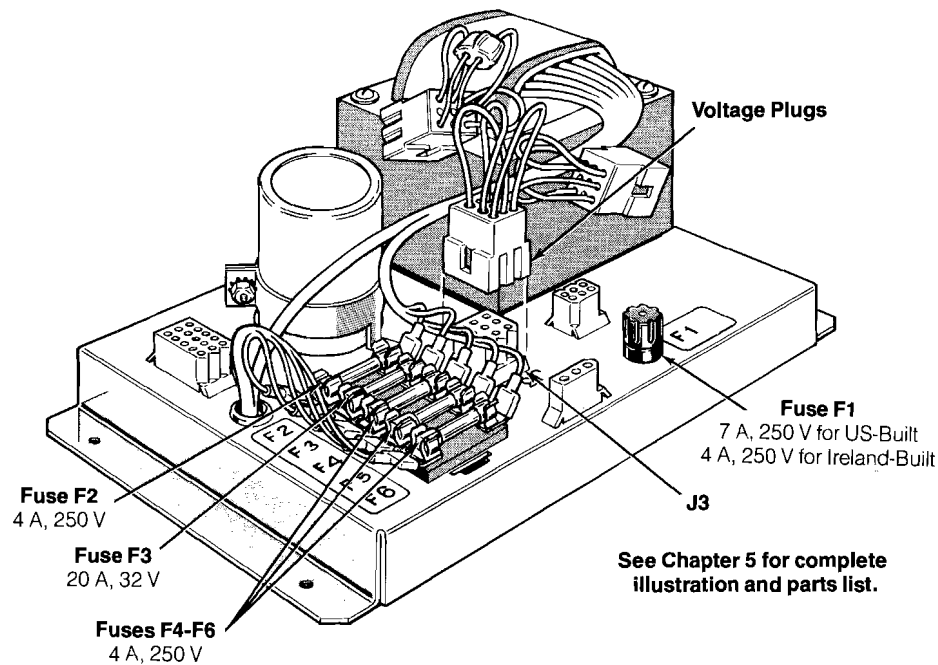
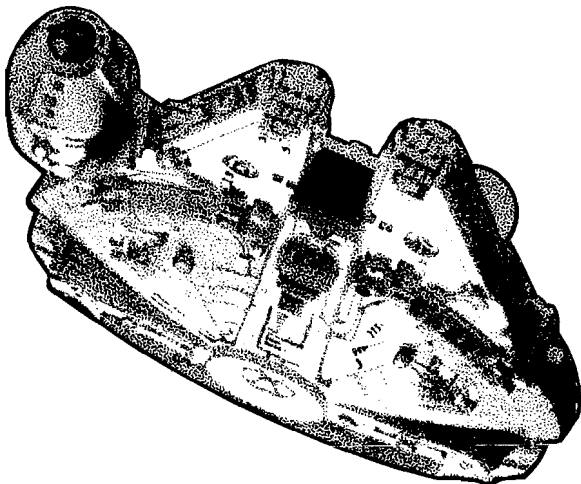

Figure 1-2 Voltage-Selection Plug and Fuse Locations

Switch Information

Power On/Off Switch

The power on/off switch is located at the bottom of the body assembly on the rear of the cabinet (see Figure 1-1).



Utility Panel Switches

The volume control, coin counter(s), self-test switch, and auxiliary coin switch are on the utility panel. The utility panel is located inside the upper coin door (see Figure 1-1). The volume control adjusts the level of sound produced by the game. The coin counter(s) records the number of coins entered into the game. The self-test switch initiates the Self-Test Mode. See Figure 5-4 for details of these switches.

Option Settings

RETURN OF THE JEDI offers Easy, Medium, or Hard game-play difficulty levels; 3, 4, 5, or 6 player lives; and a bonus (or no bonus) every 30,000, 40,000, or 50,000 points. Your game is shipped with options preset at the factory to those shown by the ◀ symbols in Tables 1-2 and 1-3. If the manufacturer's recommended settings are not satisfactory for your location, you can change the game's option settings to suit your requirements by using the information provided in Tables 1-2 and 1-3. You must enter the Self-Test Mode to change the option settings (see Chapter 2).

NOTE

For complete instructions on how to set the game's options, refer to Chapter 2 Self-Test.

Table 1-2 Coin & Credit Settings

Option	Setting
Credit Options	1 Coin
	2 Coins ◀†
	3 Coins
	4 Coins
Left Mechanism Value	1 Coin ◀†
	2 Coins
Right Mechanism Value	1 Coin ◀†
	4 Coins
	5 Coins
	6 Coins
Bonus Adder	No Bonus Coins Added ◀†
	Free Play
	1 Bonus Coin for 2 Coins
	1 Bonus Coin for 3 Coins
	2 Bonus Coins for 4 Coins
	1 Bonus Coin for 5 Coins
1 Bonus Coin for 4 Coins	

Table 1-3 Game Option Settings

Option	Setting
No. of Starting Lives	Three Lives
	Four Lives
	Five Lives ◀†
	Six Lives
Difficulty Levels	Easy†
	Medium ◀
	Difficult
Bonus Life Awarded	Every 30,000 points†
	Every 40,000 points ◀
	Every 50,000 points
Reset High Scores	Yes
	No ◀†

◀Manufacturer's recommended settings for American games.
 †Manufacturer's recommended settings for European games.

Game Play

RETURN OF THE JEDI is a one-player game. The player controls the actions of PRINCESS LEIA*, CHEWBACCA*, and LANDO CALRISSIAN* via the flight control. The player's main goal is to destroy the DEATH STAR*. To do this, the player must travel through a tube in the DEATH STAR and fire a torpedo into the central reactor.

RETURN OF THE JEDI has four modes of operation: Attract, Play, High-Score, and Self-Test. Self-Test is a special mode

for checking the game switches and computer functions, and setting the coinage and game options.

Attract Mode

The Attract Mode begins either when the game is plugged in or after exiting from the Play, High-Score, or Self-Test Modes. The Attract Mode ends either when the correct amount of credit is inserted, or when the Self-Test Mode is entered.

When the Attract Mode begins you will see the following credit lines:

RETURN OF THE JEDI
 © 1984 LUCASFILM AND ATARI
 ALL RIGHTS RESERVED

LUCASFILM TRADEMARKS USED UNDER LICENSE.

Then PRINCESS LEIA appears on a SPEEDER BIKE* traveling through the forest fighting enemy STORMTROOPERS* on SPEEDER BIKES. Then the *All-Time JEDIKNIGHTS* high-score table is displayed. Various player strategies are demonstrated and instructions are displayed.

Play Mode

RETURN OF THE JEDI picks up the action of the movie at the scene where the rebel forces begin their attack on the Imperial DEATH STAR. LUKE SKYWALKER* and PRINCESS LEIA race toward a pair of speeder bikes. In this first wave, the player controls LEIA, guiding her through a forest toward the EWOK village. She is pursued by Imperial STORMTROOPERS also riding SPEEDER BIKES. She defends herself by either bumping them off their bikes, or shooting them. Meanwhile, the EWOKS* have set up traps to aid LEIA in her flight through the forest of ENDOR. The traps include ropes stretched between trees that the EWOKS pull tight to up-end the riders, and logs that the EWOKS push together to crush the SPEEDER BIKES as they pass between them. LEIA can either bump off the STORMTROOPERS or lead them through the traps. The first vehicle through a trap will escape uninjured, but anyone who follows will be destroyed.

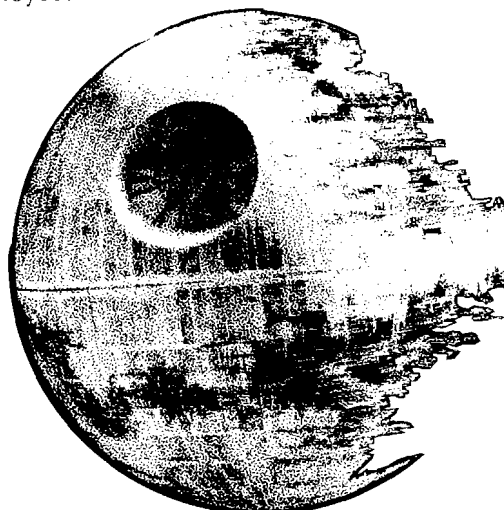

Once the player leaves LEIA safely at the EWOK village, he moves to another part of the forest. During the second wave, the player controls CHEWBACCA who is maneuvering a SCOUT WALKER to the bunker where HANSOLO* is waiting to deactivate the shield protecting the DEATH STAR. CHEWBACCA must shoot or avoid logs, which roll toward him. At the same time, CHEWBACCA must avoid rocks catapulted at his SCOUT WALKER. The player can turn the SCOUT WALKER head using the flight control to achieve better aim while firing at the rocks and logs.

The split-wave effect occurs during waves two and three. The player controls CHEWBACCA in the SCOUT WALKER, and at the same time, controls LANDO CALRISSIAN as he flies the MILLENNIUM FALCON. At crucial moments, the scene will change from the forest of ENDOR to the skies around the DEATH STAR.

While CHEWBACCA is attempting to reach the bunker, LANDO CALRISSIAN is flying the MILLENNIUM FALCON toward the DEATH STAR. LANDO must fight off the IMPERIAL T.I.E. INTERCEPTORS, IMPERIAL STAR CRUISERS, and shuttles. The player maneuvers the FALCON through this traffic, while trying to shoot as many of the Imperial enemies as possible.

As soon as CHEWBACCA gets to the bunker, HANSOLO blows it up, deactivating the protective shield surrounding the DEATH STAR and clearing the path for the MILLENNIUM FALCON. The MILLENNIUM FALCON must enter the DEATH STAR, travel down a tube toward the reactor, and shoot the central reactor to destroy the DEATH STAR.

The FALCON is pursued by IMPERIAL T.I.E. FIGHTERS* while in the tube. LANDO must avoid the pipe walls of the tube and watch out for falling pipes, energy gates, and turrets that shoot at the FALCON. Upon reaching the target, the player must shoot the reactor energy field, then immediately turn around and fly back down the tube. The flight must be rapid because the fireball caused by the explosion pursues the FALCON.

Hints for Game Play

- Do not allow enemies to tail you too long. This is how they can destroy you.
- Lead enemies to the top of the screen, then drop back quickly so you can destroy them.
- The player must try to be the first through the EWOK traps in the forest of ENDOR.
- By staying in the center of the screen, the player has more maneuverability.

High-Score Mode

RETURN OF THE JEDI has two high-score tables. The first table, *Today's REBEL FORCES*, lists the top ten scores and the players' initials for one day. The *All-Time JEDI KNIGHTS* table lists the overall top ten scores and the players' initials. In addition, if a player completes all eight levels of the game, he receives a special bonus of 100,000 points, and the message *You have completed your JEDI training*, and a star appears beside the player's initials.

The EWOK celebration music plays if the player achieves one of the top 20 scores. The player has 60 seconds to enter his initials using the flight control. By moving the flight control right or left, the player will find his desired letter. Then, by pressing a fire trigger, he can enter a letter. The player does this until he enters three letters. Afterwards, the high-score table displays his newly-entered initials.

Self-Test Mode

The Self-Test mode can be entered from all other game modes by sliding the self-test switch down on the utility panel. Self-Test allows for checking of game switches and computer functions, and setting the game and coinage options. See Chapter 2 for complete self-test information.

Self-Test

This game will test itself and provide data to show that the game circuitry and controls are operating properly. Self-test data is presented visually on the video display and audibly through the speakers. No additional equipment is required.

We suggest you perform a self-test when you first set up, each time you collect money, change the game options, or suspect game failure.

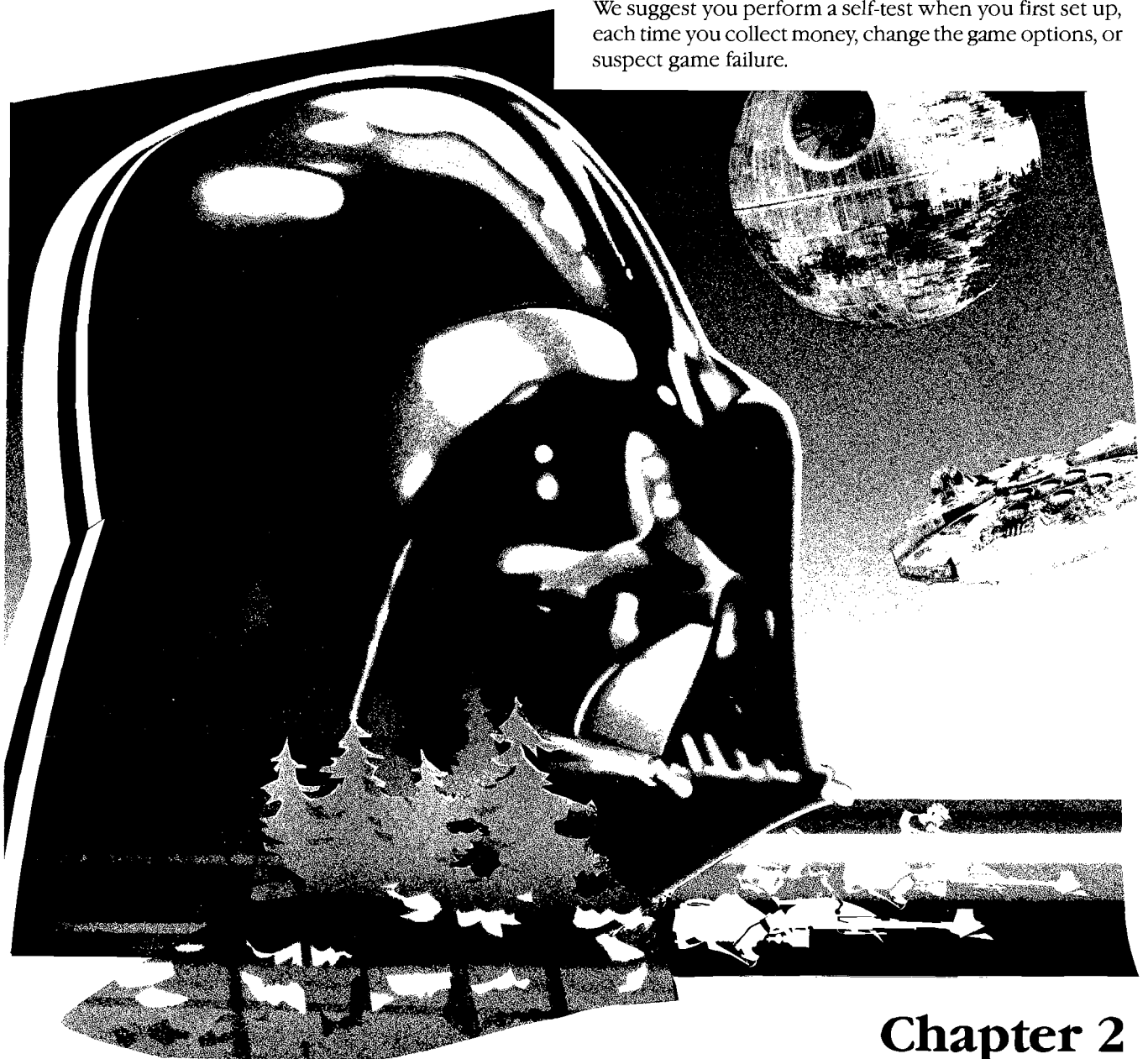

Chapter 2

Self-Test Displays

Seven self-test displays provide a visual check of the following:

- Random-access memory (RAM), read-only memory (ROM), and associated circuitry operation.
- Game statistics and options information.
- Sound-processor and associated circuitry operation.
- Flight-control and associated circuitry operation.
- Display circuitry operation.

When the self-test switch is turned on, the game enters the Self-Test Mode. The following self-test displays are arranged in the sequence in which they occur after the self-test switch (located on the utility panel behind the coin door) is turned on. After Screen 7–Grid Pattern, the sequence starts over with Screen 1–Hardware Test. Turning the self-test switch off at any time during the Self-Test Mode causes the game to return to the Attract Mode.

Screen 1–Hardware Test

The Hardware Test screen, as shown in Figures 2-1 and 2-2, provides a visual check of the game RAM, ROM, and their associated circuitry. Screen 1 is divided into RAM and ROM test sections. The condition of the RAM circuitry is displayed in the top half of the screen and, after about a one-second delay, the condition of the ROM circuitry is displayed in the bottom half of the screen. An error message indicates that the RAM, ROM, or their associated circuitry may be faulty.

If the RAM and ROM test passes, the message *ZPAGE-ALPHA-COLOR RAM OK* and five *ROM AT XX: OK*

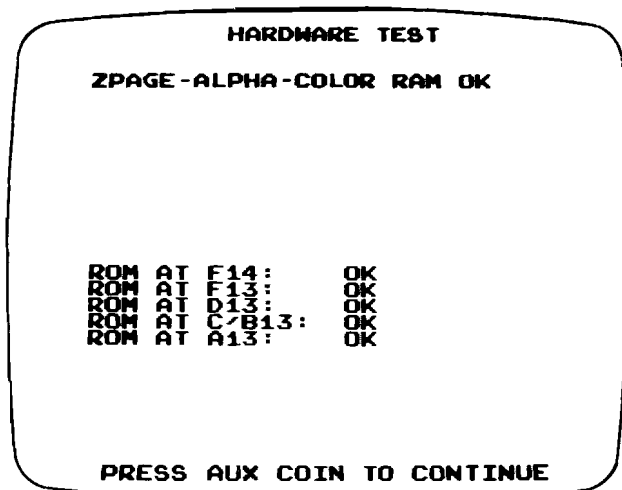

Figure 2-1 RAM/ROM Test Passes

messages will appear as shown in Figure 2-1. The *ZPAGE-ALPHA-COLOR RAM OK* message indicates that the zero page RAM at location 14B/C, the alphanumeric RAM at location 2R, and the color RAM at locations 12P, 12R, and 12S are operating properly. The *ROM AT XX: OK* messages indicate that the ROM at the specified locations are operating properly.

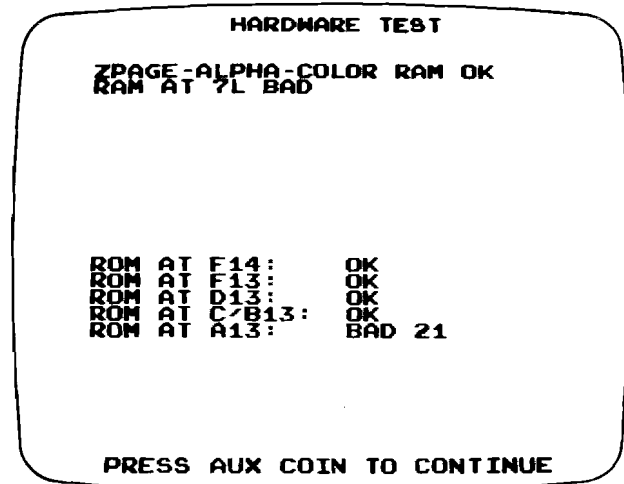

Figure 2-2 RAM/ROM Test Fails

If the RAM test fails, either a colored screen or an error message may appear. A red screen indicates a failure in the zero-page RAM circuitry; a green screen indicates a failure in the alphanumeric RAM circuit; and a magenta screen indicates a failure in the color RAM circuitry. A failure in the remaining RAM circuits tested will display a *RAM AT XX BAD* message in the top half of the screen, as shown in Figure 2-2. (Several error messages may mean a faulty address.)

If the ROM test fails, a *ROM AT XX: BAD* message will appear in the bottom half of the screen (for one or more of the five ROM tested) as shown in Figure 2-2. The number that appears after *BAD* is a diagnostic code (i.e., number 21). Disregard this number.

Press the auxiliary coin switch to obtain Screen 2.

Screen 2–Statistics

The Statistics screen, as shown in Figure 2-3, provides a visual check of the game statistics. The statistics information is accumulated either from the first time the game was turned on or from the last time the statistics were reset. (Refer to *Resetting the Statistics* for the reset procedure.)

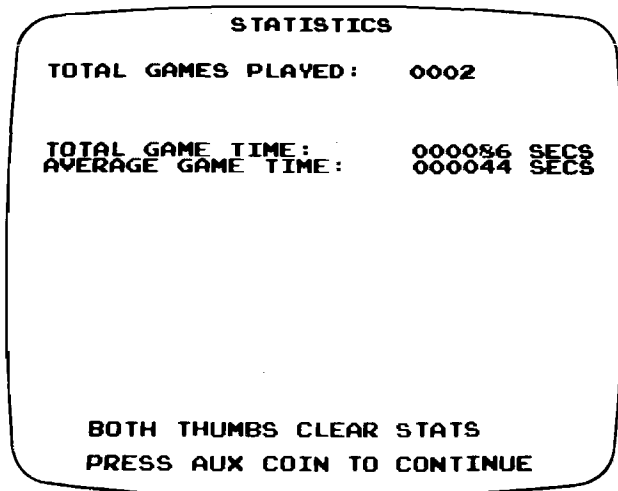

Figure 2-3 Statistics

The following information appears in the Statistics display:

- TOTAL GAMES PLAYED shows the total number of free and paid games played.
- TOTAL GAME TIME shows the total time, in seconds, of all the games played.
- AVERAGE GAME TIME shows the average time, in seconds, of all the games played.

Resetting the Statistics. The statistics information can be reset by pressing both flight-control thumb buttons simultaneously.

Press the auxiliary coin switch to obtain Screen 3.

Screen 3—Game Options

The Game Options screen, as shown in Figure 2-4, provides a visual check of the current option settings. The Op-

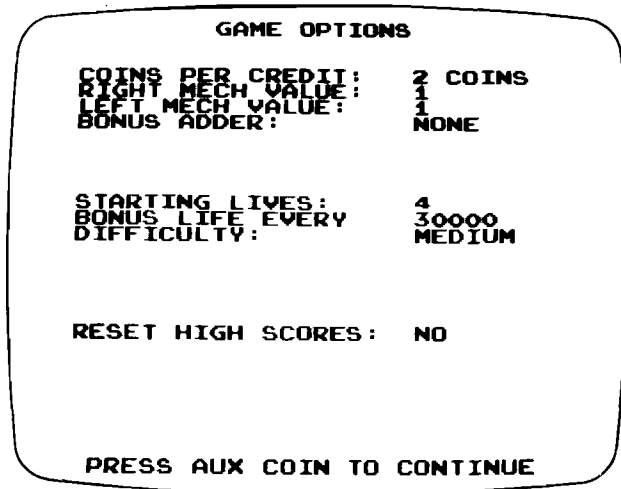

Figure 2-4 Game Options

tions display is also used to change the options or reset the top 10 high scores in the high-score table. Refer to *Resetting the High Scores* or *Changing the Options* for the appropriate procedures.

Changing the Options. Change the options by moving the flight control up or down to select the option to be changed, which is indicated by a flashing readout. Then press either fire trigger to select the desired option setting.

Resetting the High Scores. We suggest that you reset the high-score table after any changes are made to the options that may affect the average game time. The top 10 high scores displayed in the Attract Mode can be reset by pressing the fire trigger. After the readout at the bottom of the screen changes to *RESET HIGH SCORES: YES*, press the auxiliary coin switch. The readout should change to *RESET HIGH SCORES: DONE*, which indicates that the top 10 high scores have been reset. (The bottom 10 scores are retained in RAM and are reset when the game power or the self-test switch is turned on.)

Press the auxiliary coin switch to obtain Screen 4.

Screen 4—Sound Processor Test

The Sound Processor Test screen is used to verify that the sound-generating circuits are operating properly. When the display appears as shown in Figure 2-5, press the flight

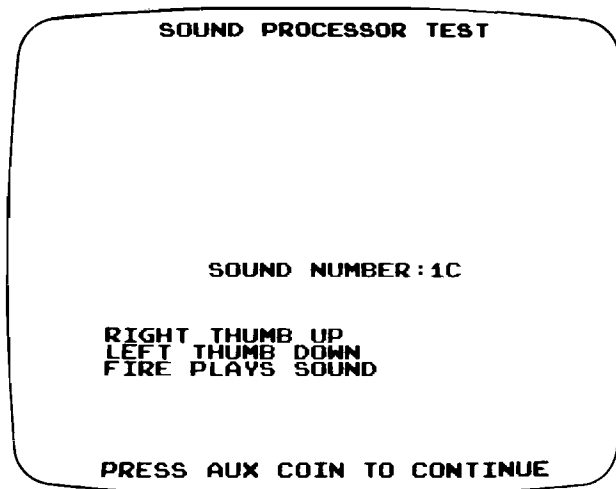

Figure 2-5 Sound Processor Test

control right or left thumb buttons to increment or decrement through the 65 available sounds, as indicated by the *SOUND NUMBER: XX* readout on the screen. (Not all the sounds are used in game play.) Press either fire trigger to start the sound. The voice segments will finish and then

repeat each time the fire trigger is pressed. The remaining sounds will stop immediately and then repeat each time the fire trigger is pressed.

If the sound-generating circuit has failed, the message *SOUND PROCESSOR BAD* will appear near the center of the screen.

Press the auxiliary coin switch to obtain Screen 5.

Screen 5—Control Test

The Control Test screen, as shown in Figure 2-6, is used to verify that the game switches are operating properly and that the flight control's vertical and horizontal ranges are within acceptable limits. Perform the following procedure to verify that the game switches and flight-control potentiometers are operating properly.

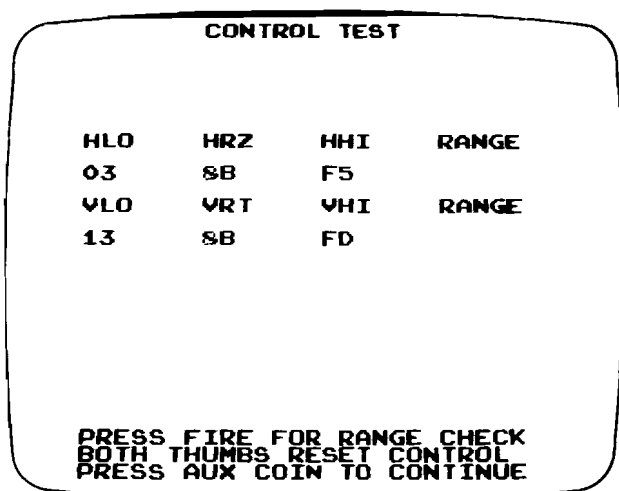

Figure 2-6 Control Test

1. Press both thumb buttons simultaneously.
2. Turn the flight control fully clockwise and hold until the horizontal high (HHI) numbers are stable (about one second).
3. Turn the flight control fully counterclockwise and hold until the horizontal low (HLO) numbers are stable (about one second).
4. Tilt the flight control to the extreme forward position and hold until the vertical low (VLO) numbers are stable (about one second).
5. Tilt the flight control to the extreme backward position and hold until the vertical high (VHI) numbers are stable (about one second).
6. Press either fire trigger and check the message under the RANGE column. If the horizontal and vertical ranges are within acceptable limits, the message *OK* should appear opposite the hexadecimal numbers for

both the horizontal and vertical ranges. If the ranges are not within the acceptable limits, the message *BAD* will appear opposite the unacceptable range(s).

NOTE

If the flight control range is not within acceptable limits, the vertical and horizontal potentiometers may be misaligned. Refer to *Aligning the Flight Control Potentiometers* in Chapter 3 for mechanical alignment procedures.

7. Actuate the right and left coin mechanisms. Note that a message appears indicating that the coin mechanisms are operating properly.
8. One at a time, press the fire triggers and thumb buttons. Note that a message appears, indicating that the fire triggers and thumb buttons are operating properly.

Press the auxiliary coin switch to obtain Screen 6.

Screen 6—Color Bars

The Color Bars screen, as shown in Figure 2-7, is used to verify that the video circuits are operating properly and that the display is adjusted for the appropriate colors. The display should contain four horizontal color bars with eight shades in each color bar. Examine the Color Bars display for the following characteristics:

- The four color bars (from top to bottom) should be red, green, blue, and gray, with each color bar becoming progressively darker from left to right. The first segment should be barely visible (view the screen with low ambient light).

The ninth column (from top to bottom) should be black, white, black, white. These are provided to show

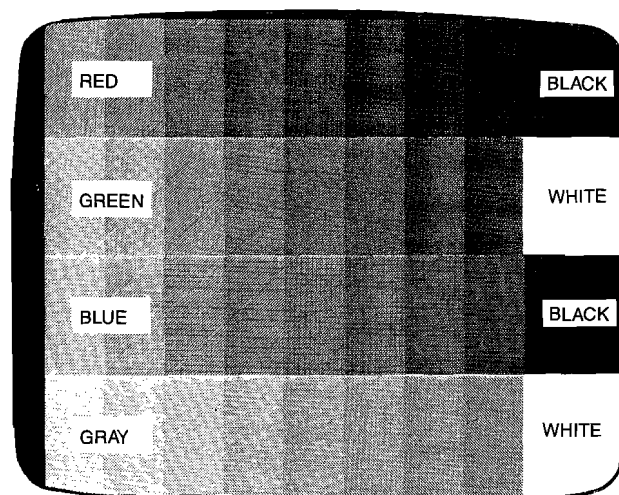

Figure 2-7 Color Bars

contrast with the eighth (darkest) column of the color bars which should show some color. All of the color bars should have the same relative intensity.

- All the color bars should have the same relative intensity.

If the display characteristics are not correct, refer to the Display Manual for the adjustment procedure or to determine the possible cause of failure.

Press the auxiliary coin switch to obtain Screen 7.

Screen 7-Grid Pattern

The Grid Pattern screen, as shown in Figure 2-8, is used to verify that the display size, centering, linearity, and convergence are properly adjusted. Examine the grid pattern for the following characteristics:

- The four solid boxes in the four corners of the frame around the grid pattern should touch all four corners of the screen.
- Grid lines should exhibit no pincushioning or barreling and the lines should be straight within 3.0 mm.
- Convergence should not exceed 2.0 mm.

If the display characteristics are not within these limits, refer to the Display Manual for the linearity and conver-

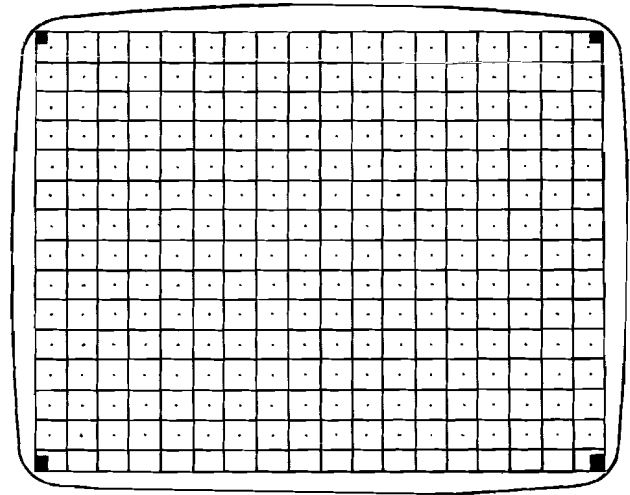

Figure 2-8 Grid Pattern

gence adjustment procedures or to determine the possible cause of failure.

NOTE

Press the auxiliary coin switch after Screen 7-Grid Pattern, to repeat the self-test sequence beginning with Screen 1-Hardware Test.



Maintenance

This chapter includes preventive and corrective maintenance procedures for game components that are subject to the most use. To assure maximum trouble-free operation from this game, Atari recommends that preventive maintenance be performed as described in this chapter.

Removal, disassembly, reassembly, and replacement procedures are provided for components that may require corrective maintenance. Appropriate references are provided to Chapter 5 Illustrated Parts Lists, to aid in locating the parts of this game that are mentioned, but not illustrated, in the maintenance procedures.

▲ — WARNING — ▲

To avoid possible electrical shock hazard, unplug the game prior to performing any maintenance.

Chapter 3

Preventive Maintenance

Preventive maintenance includes cleaning, lubricating, and tightening hardware. How often preventive maintenance is performed depends upon the game environment and frequency of play. However, for those components listed in *Table 3-1 Preventive-Maintenance Intervals*, we recommend that preventive maintenance be performed at the intervals specified.

Preventive-Maintenance Intervals

The preventive-maintenance intervals specified in Table 3-1 are the recommended minimum requirements for the components listed.

Table 3-1 Recommended Preventive-Maintenance Intervals

Component	Maintenance Interval
Flight Control	Lubricate and tighten hardware at least every three months.
Coin Mechanism	Clean at least every three months.

⚠ WARNING ⚠

To avoid possible electrical shock, turn off and unplug the game before performing any maintenance procedures.

Removing the Control Panel

Perform the following procedure to remove the control panel from the cabinet (see Figure 3-1).

1. Turn the game power off.
2. Unlock and open the coin door on the front of the cabinet.
3. Carefully reach through the coin door opening and release the spring-draw latches located under the control panel on both sides of the cabinet.
4. Lift the front of the control panel and slide it toward you to clear the flight-control assembly from the cabinet.
5. Hook the bracket (located on the underside of the control panel) onto the front edge of the cabinet. Disconnect the flight-control harness connector before moving the control panel to a work surface.

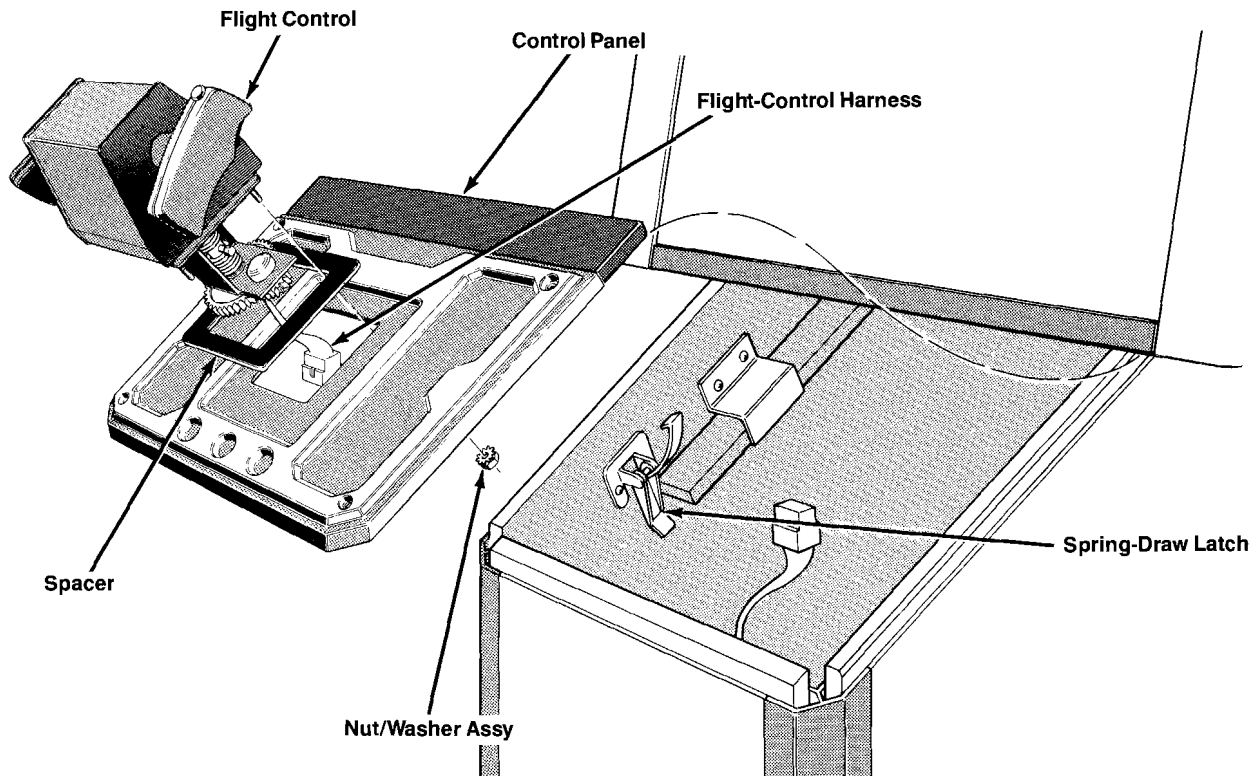
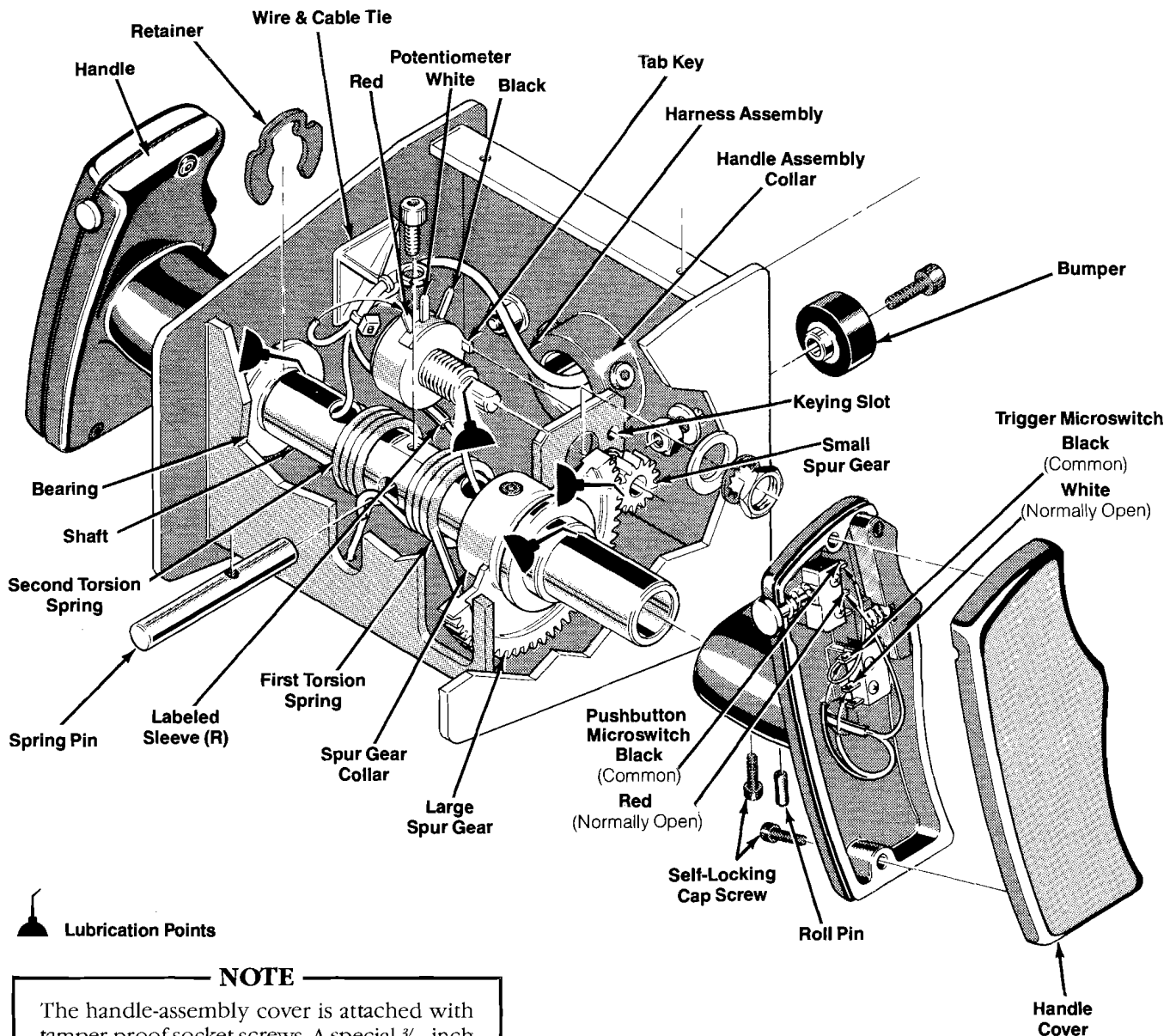

Figure 3-1 Removing the Control Panel and Flight Control

**NOTE**

The handle-assembly cover is attached with tamper-proof socket screws. A special $\frac{3}{32}$ -inch hex-key tool is supplied with each game (Atari part no. 178126-001) for removing the tamper-proof socket screws.

Figure 3-2 Handle Assembly

Lubricating the Flight Control

Perform the following procedure to lubricate the flight control. Lubrication can be performed without removing the flight-control assembly from the control panel. See Figures 3-2 and 3-3 for the location of the lubrication points and parts mentioned in the following procedure.

1. Remove the control panel as previously described.
2. Use the special $\frac{3}{32}$ -inch hex-key tool to remove the four tamper-proof socket screws from the handle-assembly cover.

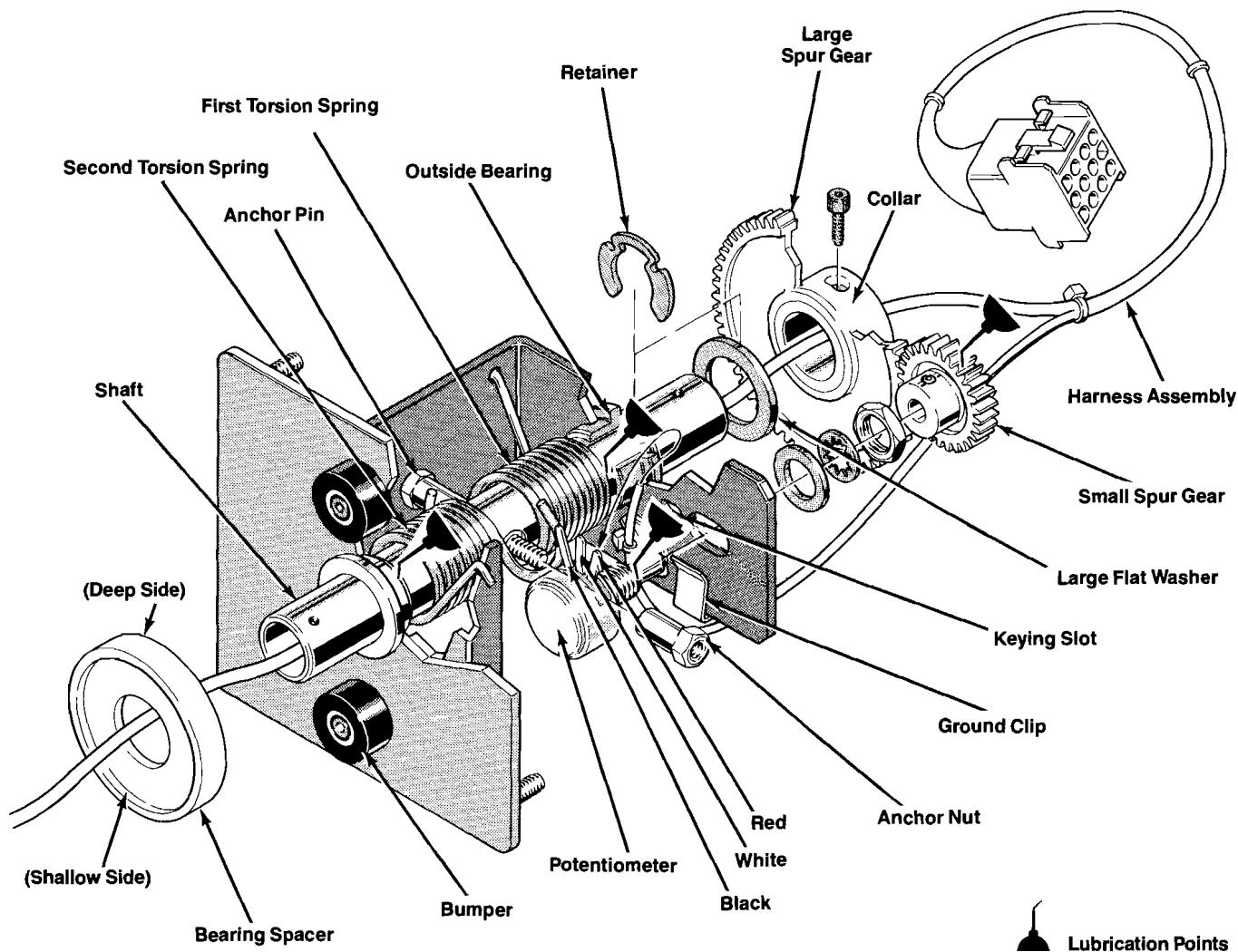

Figure 3-3 Steering Assembly

3. Lift the cover from the handle assembly and lubricate the following parts inside the flight control (see the oil can symbols in Figures 3-2 and 3-3).
 - a. Apply two drops of light machine oil (Atari part no. 107013-001) to the potentiometer shafts and to the four main shaft bearings.
 - b. Brush a light film of Nyogel 779 lubricant (Atari part no. 178027-001) over the outside of the four torsion springs and on the teeth of the two small spur gears.

Tightening the Flight-Control Hardware

Use the appropriate hex driver and combination wrenches to tighten all the flight control screws and mounting nuts (see Figures 3-1, 3-2, and 3-3).

Cleaning the Coin Mechanism

Use a soft-bristled brush to remove loose dust or foreign material from the coin mechanism. A toothbrush may be used to remove any stubborn build-up of residue in the coin path. After cleaning the coin mechanism, blow out all of the dust with compressed air.

Cleaning the Cabinet and Display Shield

The game cabinet and display shield may be cleaned with any non-abrasive household cleaner. Compressed air is recommended for cleaning dust from the interior of the cabinet.

Corrective Maintenance

Corrective maintenance consists of removal, disassembly, reassembly, and replacement of game components. The following procedures are provided for components that may require corrective maintenance.

Flight Control

The following corrective maintenance procedures apply to the flight control. The flight control consists of a handle assembly and a steering assembly. The handle assembly controls the vertical motion, and the steering assembly controls the horizontal motion of the graphics on the display. After any corrective maintenance is performed, the flight control should be recalibrated as described in this chapter under *Calibrating the Flight Control*.

Removing the Flight Control

NOTE

The handle assembly can be disassembled with the flight control attached to the control panel. However, for convenience and to avoid damaging the control panel, we recommend that the flight control be removed from the game before any corrective maintenance or repair is performed.

Perform the following procedure to remove the flight control from the control panel (see Figure 3-1).

1. Remove the control panel as previously described.
2. Disconnect the flight-control harness assembly.
3. Use a $\frac{7}{16}$ -inch combination wrench to remove the four locknuts and washers that secure the flight control to the control panel.
4. Carefully remove the flight control from the control panel.
5. To reinstall the flight control, guide the flight control back into the control panel.
6. Attach the four locknuts and washers that mount the flight control to the control panel.
7. Reconnect the flight-control harness assembly.
8. Reinstall the control panel.

Removing the Handles

Perform the following procedure to remove the handles from the handle assembly (see Figure 3-2).

1. Use a $\frac{3}{4}$ -inch hex driver to remove the four cap screws that hold the covers onto the handles. Be careful when

removing the covers because the trigger and pushbutton springs can fall off the handles.

2. Unsolder the three harness wires from the trigger and pushbutton microswitches inside each handle and pull the harness out of the shaft.
3. Use a $\frac{3}{4}$ -inch hex driver to remove the four cap screws that hold the handles onto the shaft.
4. Use a $\frac{3}{16}$ -inch punch to drive the roll pin (located between the two cap screws) into the hollow of the shaft. Remove the roll pin from the shaft.
5. Gently slide the handles from the shaft.
6. To reinstall the handles, solder the three harness wires from the trigger and pushbutton microswitches.
7. Reinstall the roll pin.
8. Replace the trigger, pushbutton springs, retaining ring, bushing, and button. Reinstall the cap screws that hold the covers onto the handles.
9. Reinstall the four cap screws that secure the handles to the shaft.

Disassembling the Handle Assembly

Perform the following procedure to disassemble the handle assembly (see Figure 3-2).

NOTE

It is not necessary to remove the handle assembly from the steering assembly to perform the following disassembly procedure. However, if you prefer, refer to steps 1 through 4 under *Disassembling the Steering Assembly* for the procedure that describes how to separate the two assemblies.

1. Use the special $\frac{3}{32}$ -inch hex-key tool to remove the four tamper-proof cap screws from the handle-assembly cover.
2. Remove the handles as previously described.
3. Gently pull the harness wires out of the hollow shaft.
4. Use a $\frac{3}{4}$ -inch hex driver to remove the cap screw and washer that hold the spring pin to the handle-assembly shaft.
5. Slide the spring-handle pin out of the shaft.
6. Use a $\frac{3}{4}$ -inch hex driver to loosen the cap screw that holds the large spur gear to the shaft.
7. Slide the large (60-tooth) spur gear down the shaft to expose the shaft retainer on the right side.

▲ **WARNING** ▲

Shield your face and eyes when prying out the retainers because they can fly loose at a high speed. Cover the retainers with a piece of cloth to trap the retainers.

8. Use a right-angle slotted screwdriver to pry the retainer from the shaft.
9. Repeat step 8 to remove the retainer on the left side of the shaft.
10. Gently slide the shaft from the housing.
11. Use a $\frac{1}{64}$ -inch hex driver to loosen the cap screw that holds the small (14-tooth) spur gear to the potentiometer shaft.
12. Use a $\frac{1}{2}$ -inch combination wrench to remove the nut and washer that hold the potentiometer to the mounting bracket.
13. Slide the potentiometer from the bracket. Be careful not to lose the small spur gear, nut, and washer.
14. Use a $\frac{5}{32}$ -inch hex-driver and $\frac{3}{8}$ -inch combination wrench to remove the two bumpers from the frame.
15. Reassemble the handle assembly as described in the following procedure.
10. Slide the shaft through the second torsion spring and the left bearing.
11. Position the shaft so that the retainer grooves are just inside the bearings.
12. Install the two retainers into the shaft grooves.
13. Turn the shaft so that the two large holes and the smaller centered hole are facing upward.
14. Locate the hole in the spring pin. Insert the end of the spring pin that is closest to the hole through the slot in the frame and through the hole in the shaft. Make sure both torsion spring looped ends are wrapped over the spring pin.
15. Position the spring pin so that the hole in the pin is aligned with the hole in the shaft.
16. Use a $\frac{1}{64}$ -inch hex driver to tighten the cap screw and washer that secure the pin to the shaft.
17. Align the cap screw in the spur-gear collar with the threaded hole in the shaft and use a $\frac{1}{64}$ -inch hex driver to tighten the cap screw.
18. Insert the potentiometer shaft through the hole in the mounting bracket. Before fully inserting the shaft through the bracket, place the washer, nut, and small (14-tooth) spur gear (with the collar facing inward) onto the shaft.
19. Align the potentiometer so that the tab key is inserted into the keying slot.

Reassembling the Handle Assembly

Perform the following procedure to reassemble the handle assembly (see Figure 3-2).

1. Use a $\frac{5}{32}$ -inch hex driver and $\frac{3}{8}$ -inch combination wrench to install the two bumpers on the frame.
2. Insert the large (60-tooth) spur gear with the collar facing away from the bearing. Align and hold the gear in line with the bearing hole. (The gear fits through the slot on the right front of the frame.)
3. Slide the shaft through the right bearing and the spur gear. Do not insert the shaft past the outside edge of the spur-gear collar.
4. Apply a heavy film of Nyogel 779 lubricant (Atari part no. 178027-001) to the inside of the torsion spring.
5. Hook the straight end of the first torsion spring through the hole closest to the right side of the frame.
6. Hold the first torsion spring in line with the shaft so that the looped end of the spring is facing away from the spur gear.
7. Slide the shaft just through the first torsion spring.
8. Hook the straight end of the second torsion spring through the hole closest to the left bearing.
9. Hold the second torsion spring in line with the shaft so that the looped end of the spring is facing the first torsion spring.
20. Use a $\frac{1}{2}$ -inch combination wrench to loosely secure the nut on the potentiometer shaft.
21. Turn the potentiometer shaft so that the flat side faces the center wire terminal.
22. Align the cap screw on the small (14-tooth) spur gear with the flat side of the shaft. Use a $\frac{1}{64}$ -inch hex driver to tighten the cap screw.
23. Slide the potentiometer forward so that the teeth on the two spur gears are tightly meshed; then slide the potentiometer and small (14-tooth) spur gear about $\frac{1}{4}$ inch away from the large spur gear.
24. Use a $\frac{1}{2}$ -inch combination wrench to tighten the potentiometer to the mounting bracket.
25. Install the harness assembly as described later in this chapter.
26. Install the handles in the reverse order of the removal procedure. Do not install the handle covers until the harness is installed and the proper wires are soldered to the trigger and pushbutton microswitches.
27. Check the vertical potentiometer alignment as described in this chapter under *Aligning the Flight-Control Potentiometers*.
28. Install the handle-assembly cover and use a $\frac{3}{32}$ -inch hex-key tool to tighten the four tamper-proof socket screws that secure the cover to the handle assembly.

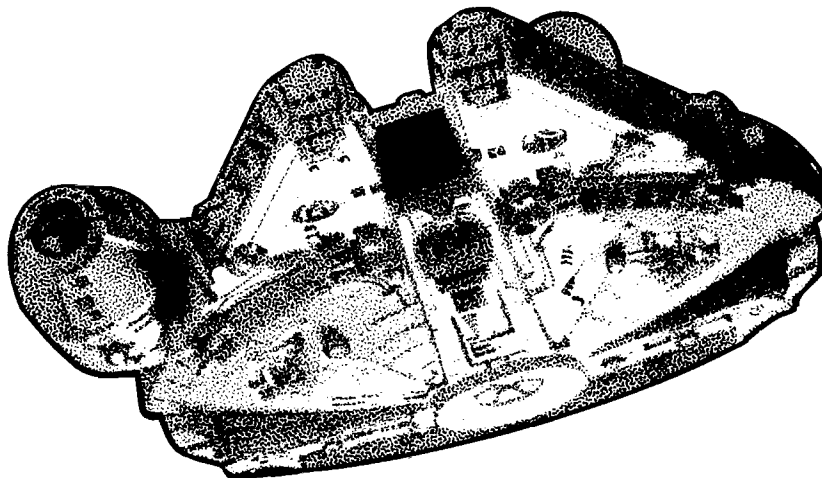

Disassembling the Steering Assembly

Perform the following procedure to disassemble the steering assembly (see Figures 3-2 and 3-3).

1. Remove the handle covers as previously described in this chapter. Be careful when opening the handles because the pushbutton and trigger springs may fall out.
2. Unsolder the three harness wires from the vertical potentiometer and the handle pushbutton and trigger microswitches.
3. Use a $\frac{5}{32}$ -inch hex driver to remove the three cap screws and lock washers that hold the steering-assembly shaft to the handle-assembly frame.
4. Gently pull the two assemblies apart. Make sure the harness wires are free to slide out of the handle-assembly shaft.
5. Use a $\frac{5}{16}$ -inch wrench to remove the anchor nut on the end of the anchor pin. (The anchor nut faces the open end of the frame.)
6. Slide the anchor pin from the shaft.
7. Grasp the large (60-tooth) spur gear and slide the shaft from the frame. The bearing spacer and torsion springs will fall free.
8. Use a $\frac{7}{64}$ -inch hex driver to remove the cap screws that hold the large spur gear to the steering shaft and the small spur gear to the potentiometer shaft.
9. Use a $\frac{1}{2}$ -inch combination wrench to remove the nut and washer that hold the potentiometer to the frame.
10. Unsolder the three harness wires from the potentiometer terminals.

▲ — WARNING — ▲

Shield your face and eyes when prying the retainer from the shaft because the retainer can fly loose at a high speed. Cover the retainer with a piece of material that will trap the retainer.

11. Use a slotted screwdriver to remove the retainer from the shaft.
12. Use a $\frac{5}{32}$ -inch hex driver and $\frac{3}{8}$ -inch combination wrench to remove the two bumpers from the frame.
13. Reassemble the steering assembly as described in the following procedure.

Reassembling the Steering Assembly

Perform the following procedure to reassemble the steering assembly (see Figure 3-3).

1. Use a $\frac{5}{32}$ -inch hex driver and $\frac{3}{8}$ -inch combination wrench to install the two bumpers to the frame.
2. Snap the retainer into the groove of the shaft and slide the large, flat washer down the long end of the shaft and against the retainer.
3. Apply a heavy film of Nyogel 779 lubricant (Atari part no. 178027-001) to the inside of the torsion springs.
4. Hook the straight end of the first torsion spring through the hole closest to the back of the frame. Slide the shaft through the outside bearing and the first torsion spring.

5. Hook the second torsion spring through the hole on the opposite side and closest to the front of the frame. Slide the shaft through the second spring and the opposite bearing.
6. Turn the shaft so that the threaded hole at the retainer end of the shaft faces up toward the open side of the frame. (The hole through the center of the shaft will then be perpendicular to the open side of the frame.)
7. Use a $\frac{5}{16}$ -inch combination wrench to install the anchor pin and nut through the hole in the center of the shaft. Make sure the looped ends of the torsion spring are wrapped under the anchor pin and nut.
8. Slide the large (60-tooth) spur gear onto the shaft with the collar facing outward.
9. Align the cap screw in the spur-gear collar with the threaded hole in the shaft, and use a $\frac{3}{64}$ -inch hex driver to tighten the cap screw.
10. Insert the potentiometer shaft through the hole in the frame and align the potentiometer so that the tab key is inserted into the keying slot.
11. Install the washer and nut on the potentiometer shaft, but do not tighten.
12. Turn the potentiometer shaft so that the flat side faces the center wire terminal.
13. Align the cap screw on the small (28-tooth) spur gear with the flat side of the shaft and slide the small spur gear (with the collar facing inward) onto the potentiometer shaft.
14. Position the spur gear so that its teeth mesh with those of the large spur gear and use a $\frac{3}{64}$ -inch hex driver to tighten the cap screw.
15. Slide the potentiometer forward so that the teeth on the two spur gears are tightly meshed; then slide the

potentiometer and small spur gear about $\frac{1}{8}$ -inch away from the large spur gear.

16. Use a $\frac{1}{2}$ -inch combination wrench to tighten the potentiometer to the frame.
17. Slide the bearing spacer over the shaft at the end opposite the spur gears. Check to make sure that the deep side of the bearing spacer sits over the head of the bronze flange bearing in the steering-assembly frame.
18. If necessary, lubricate the steering assembly as previously described in this chapter.

NOTE

The remaining steps describe the procedure for attaching the steering assembly to the handle assembly.

19. Insert the steering-assembly shaft into the collar on the handle-assembly frame.
20. Align the three holes in the steering-assembly shaft with the three holes in the handle-assembly collar.
21. Use a $\frac{5}{32}$ -inch hex driver to tighten the three cap screws and lock washers. Be sure the screws are tight.
22. Install the harness assembly as described in the following procedure.
23. Check the horizontal potentiometer alignment as described under *Aligning the Flight-Control Potentiometers*.

Installing the Harness Assembly

Perform the following procedure to install the harness assembly to the flight control (see Figures 3-2 and 3-3).

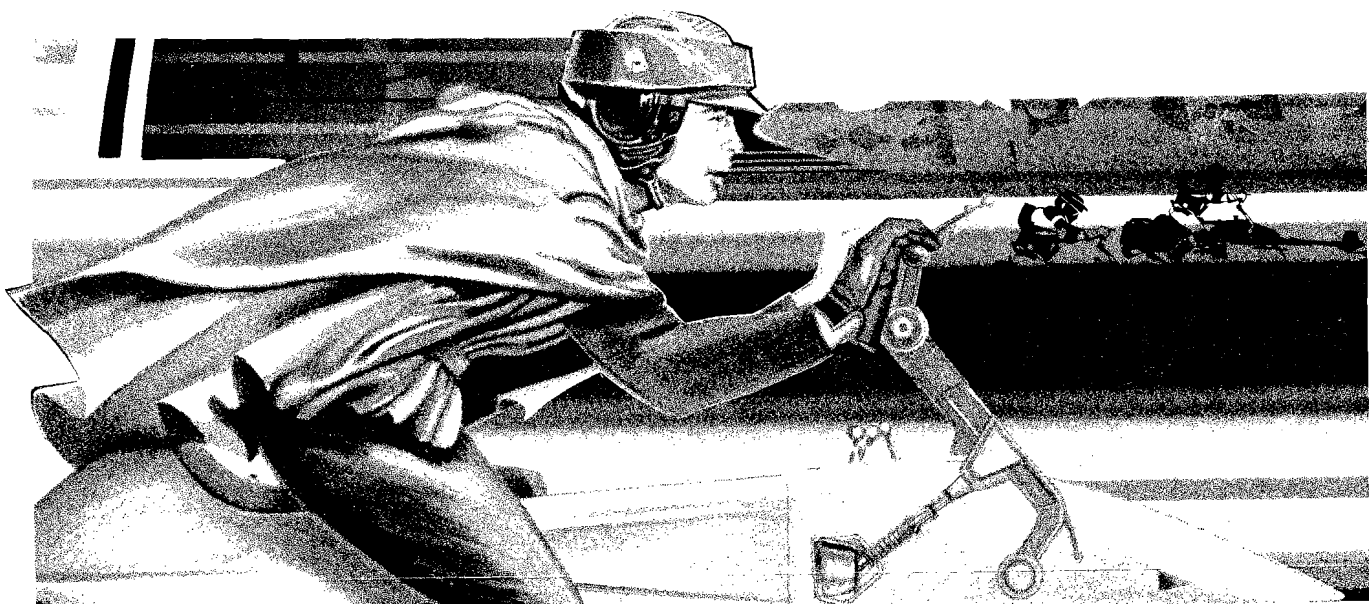

1. If necessary, remove the handle covers as described under *Removing the Handles*.
2. Guide the harness wires into the spur-gear end of the hollow steering-assembly shaft. The wires for the steering, horizontal potentiometer, and grounding clip should remain outside of the shaft.
3. Route and solder the wires to the potentiometers and microswitches. Note that the wire bundle that goes to the right handle is identified with a labeled sleeve (R).
4. Install the wire ties and the ground clip. Make sure the wires do not interfere with the gears when the flight-control assembly is mounted.
6. Gently slide the potentiometer forward so that the spur-gear teeth are tightly meshed. (If necessary, slightly move the large gear to align the gear teeth—do not turn the potentiometer shaft.) Recheck the Control Test display limits.
7. Pull the potentiometer and small spur gear about $\frac{1}{4}$ inch away from the large spur gear. Use a $\frac{1}{2}$ -inch combination wrench to tighten the potentiometer to the mounting bracket.
8. Install the handle-assembly cover by using the special $\frac{3}{32}$ -inch hex-key tool to tighten the tamper-proof socket screws.

Aligning the Flight-Control Potentiometers

The following procedures describe the method for checking and aligning the vertical and horizontal flight-control potentiometers to ensure that the player-controlled object on the display is centered when the flight control is released.

Preliminary Procedure

Perform the following procedure to determine if the vertical and/or horizontal potentiometers are misaligned.

1. Turn off the game power.
2. Set the self-test switch to the on position.
3. Turn on the game power.
4. Perform the Control Test display procedure for checking the flight control range as described in Chapter 2. If the self-test display indicates that the flight-control vertical or horizontal range is out of tolerance, perform the appropriate procedure as follows.

Vertical Potentiometer

Perform the following procedure to align the flight-control vertical potentiometer (see Figure 3-2).

1. Turn off the game power.
2. If necessary, remove the flight-control handle-assembly cover with the special $\frac{3}{32}$ -inch hex-key tool to gain access to the vertical-motion potentiometer.
3. With the flight control centered (no tension on the return springs), check that the set screw on the potentiometer spur gear is facing the center (white) wire terminal. If it is not, use a $\frac{1}{2}$ -inch combination wrench and loosen the potentiometer mounting nut. Slide the potentiometer sideways in the mounting bracket until the gears disengage.
4. Turn on the game power.
5. Turn the small spur gear until the Control Test display (obtained in the Preliminary Procedure) indicates that the vertical potentiometer is within the allowable limits.

Horizontal Potentiometer

Perform the following procedure to align the horizontal potentiometer (see Figure 3-3).

1. Turn off the game power.
2. Remove the control panel as previously described.
3. With the flight control centered (no tension on the springs), check that the set screw on the potentiometer spur gear is facing the center (white) wire terminal. If not, use a $\frac{3}{64}$ -inch hex driver and loosen the set screw on the potentiometer spur gear. Slide the spur gear off of the potentiometer shaft.
4. Turn on the game power.
5. Turn the potentiometer shaft until the Control Test display (obtained in the Preliminary Procedure) indicates that the horizontal range is within the allowable limits.
6. Slide the spur gear onto the potentiometer with the set screw centered over the flat side of the shaft. Align the gear teeth so they mesh with the large spur gear. (If necessary, the large spur gear can be turned slightly—do not turn the potentiometer shaft.)
7. Use the $\frac{3}{64}$ -inch hex driver and tighten the spur-gear set screw. Recheck the Control Test display to make certain the horizontal range is still within the allowable limits.

Calibrating the Flight Control

The flight control is self-calibrating. The game circuitry monitors the control and calibrates the potentiometers. Calibrate the flight control after any corrective maintenance is performed by moving the flight control to the extreme right, left, up, and down positions. This should be repeated several times. Players also calibrate the control during normal game play, but it may take several seconds of game play to be optimized. If the player-controlled object fails to return to center screen when the flight control is released, check the flight control vertical and horizontal range as previously described in this chapter.

Removing the Display Shield and Bezel

Perform the following procedure to remove the display shield and bezel from the cabinet (see Figure 3-4).

1. Use a Phillips-head screwdriver to remove the display access panel from the rear of the game cabinet.
2. From the front of the cabinet, use a $\frac{1}{8}$ -inch Allen wrench to remove the upper retainer of the attraction panel. Save the hardware for reassembly.
3. Slide the attraction panel and the semi-rigid film (behind the panel) up and out of the left and right caps.

NOTE

Moldings are firmly fitted on each side of the attraction panel and on each side of the display shield. These moldings should stay on the attraction panel and display shield.

4. Remove the H-shaped retainer between the attraction panel and the display shield.
5. Slide the display shield up and out of the right and left caps. If necessary, loosen the lower retainer to break the foam tape seal on the bottom of the display shield.
6. Carefully remove the display bezel.

Removing the Display

Perform the following procedure to remove the display from the cabinet (see Figure 3-4).

1. Turn the game off and wait approximately two minutes. Unplug the game.
2. Remove the display shield and bezel as previously described.
3. Use a Phillips-head screwdriver to remove the four screws securing the right and left caps to the cabinet.
4. Discharge the high-voltage from the cathode-ray tube (CRT) before proceeding. The display assembly contains a circuit for discharging the high voltage to ground when power is removed. However, to make certain, always discharge the display as follows.
 - a. Attach one end of a large, well-insulated, 18-gauge jumper wire to ground.
 - b. Momentarily touch the free end of the grounded jumper to the CRT anode by sliding it under the anode cap.
 - c. Wait two minutes and repeat part b.
5. From the back of the cabinet, open the rear access panel. Unplug the display-harness connectors and disconnect the ground wire.
6. From the front of the cabinet, remove the hardware that secures the video display to the cabinet. Save this hardware for reassembly.
7. Carefully remove the display through the front of the cabinet. Place it on a soft mat in a protected location.

NOTE

Whenever the video display is replaced re-adjust the brightness, purity, and convergence as described in the display manual.

WARNING

High Voltage

This display contains lethal high voltages. To avoid injury, do not attempt to service this display until you observe all precautions necessary for working on high-voltage equipment.

X-Radiation

This display has been designed to minimize X-radiation. However, to avoid possible exposure to soft X-radiation, NEVER modify the high-voltage circuitry.

Implosion Hazard

The cathode-ray tube may implode if struck or dropped. Shattered glass may cause injury within a 6-foot radius. Use care when handling the display.

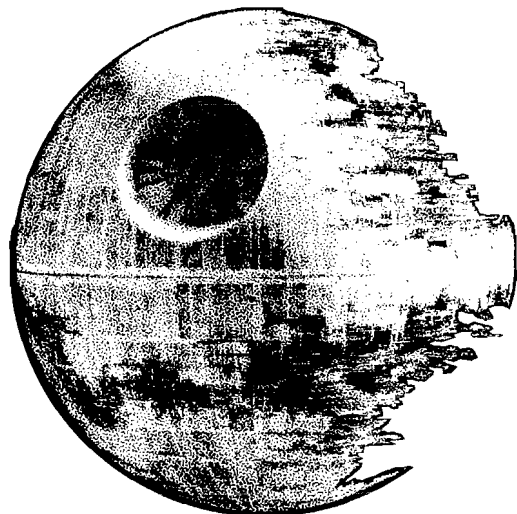

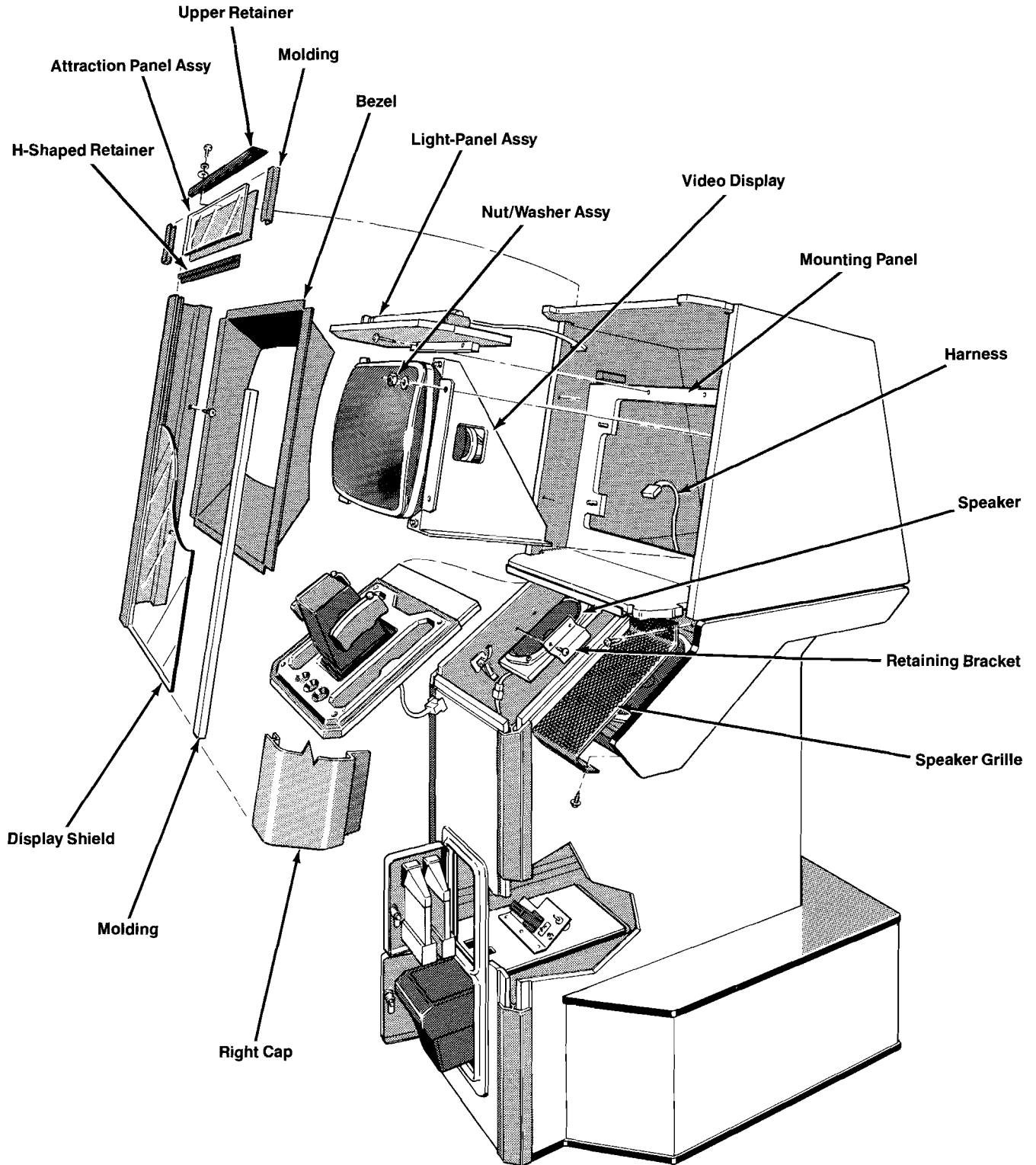

Figure 3-4 Removing the Video Display and Light-Panel Assembly

Removing the Light-Panel Assembly

Perform the following procedure to remove the light-panel assembly from the cabinet (see Figure 3-4).

1. Remove the display shield and bezel as previously described.
2. Use a Phillips-head screwdriver to remove the four screws securing the right and left caps to the cabinet.
3. Disconnect the harness from the light-panel assembly.
4. Use a Phillips-head screwdriver to remove the two screws securing the cleat to the top of the display-mounting frame.
5. Slide the light-panel assembly out of the front of the cabinet.

Removing the Speakers

Perform the following procedure to remove the speakers from the cabinet (see Figure 3-4).

1. Remove the control panel as previously described.
2. Use a Phillips-head screwdriver to remove the four screws securing the speaker grille to the cabinet.
3. From inside the control-panel opening, use a Phillips-head screwdriver to remove the two screws securing the speaker retaining bracket to the cabinet.

CAUTION

Do not touch the speaker cones when handling the speakers. The cone material is fragile and can be easily damaged.

4. Slide the speaker and mounting board sideways through the slot in the cabinet.
5. Disconnect the speaker-harness connector.
6. Use a Phillips-head screwdriver to remove the four screws securing the speaker to the mounting board.

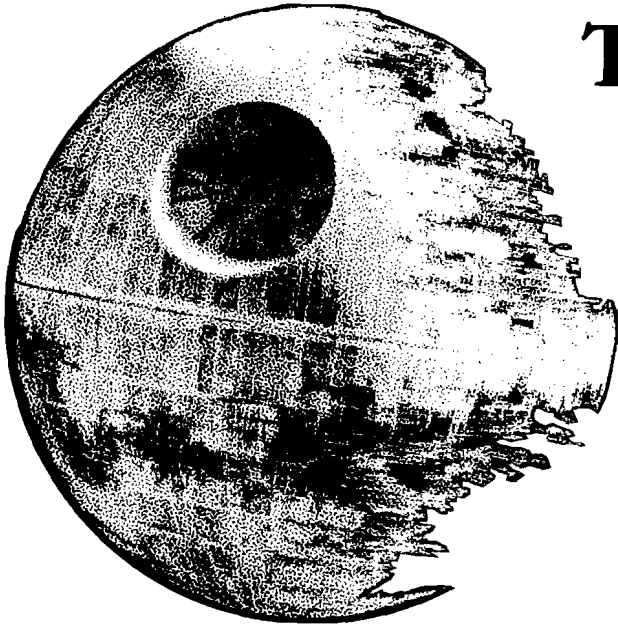

Troubleshooting

This chapter contains a discussion of troubleshooting aids and techniques to assist the service technician when a trouble is suspected in this game. Most troubles can be located quickly by following the information in this chapter. However, if problems persist, contact your nearest Atari Customer Service office listed on the inside front cover of this manual for assistance.

A thorough knowledge of game operation is desirable for effective troubleshooting. In addition to the operation and service information in the Schematic Package Supplement included with this manual, refer to *The Book, A Guide To Electronic Game Operation and Servicing*. This publication is available from Atari, Inc., and has more information on coin-operated electronic games.

NOTE

We recommend that troubleshooting and repair procedures be performed by a qualified electronic technician.

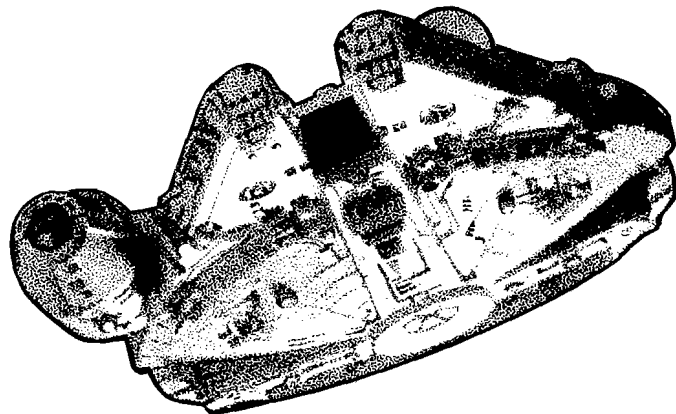

Troubleshooting Aids

Troubleshooting aids are provided throughout this manual and the Schematic Package Supplement. The following information is intended to acquaint the service technician with portions of these documents that contain useful troubleshooting and repair information.

Assembly and Component Locations

The parts lists in Chapter 5 illustrate the locations of assemblies and components. Printed-circuit board (PCB) illustrations aid in rapidly locating components shown on the corresponding schematic diagram(s).

Diagrams

The Schematic Package Supplement included with this game contains schematic diagrams with component locations, active component type numbers, and electrical values.

Troubleshooting Procedures

Refer to the following section, *Troubleshooting Techniques*, for a suggested troubleshooting sequence to aid in locating defective components.

Troubleshooting Techniques

▲ — WARNING — ▲

To avoid electrical shock, turn off the game power before attempting to troubleshoot this game.

The following troubleshooting steps are arranged in a sequence recommended for locating a defective component. The procedure begins with a check of the simple trouble possibilities and progresses to more extensive procedures for localizing the problem to an assembly or major circuit, and then to a defective component.

Check Switch Settings

Incorrect switch settings can sometimes indicate a problem that does not exist. Refer to Chapter 1 to verify that the game has been installed properly and the option settings are correct. Refer to Chapter 2 for instructions on how to set the option settings. Check for proper operation in all game-play modes.

Check Fuses

Check for open fuses. Refer to Chapter 5 and the Display Manual for the location and rating of each fuse used in this game. Make sure that replacement fuses are the proper type and rating.

Check Power-Supply Voltages

Improper operation of all circuits usually indicates a power supply problem. Be sure that the proper line voltage is available to the power supply. Check for correct voltages.

Localize Trouble

Determine the trouble symptom. Use the wiring diagrams in the Schematic Package Supplement to determine which assemblies or major circuits could cause the trouble. Perform the self-test procedure provided in Chapter 2.

Visual Check

Visually check for obvious problems in the portion of the game where the trouble is suspected. For example, check for loose or defective solder connections, integrated circuits loose in their sockets, loose cable connections, broken wires, and damaged components.

Check Individual Components

Check soldered-in passive components (e.g., resistors, capacitors, diodes) by disconnecting one end to isolate the measurement from the effects of the surrounding circuitry. Often, direct substitution is the most practical way to determine if a component is faulty. However, eliminate the possibility of some other circuit problem that could damage the substitute component.

Repair the Assembly

— CAUTION —

Soldered-in transistors and integrated circuits are difficult to remove without damaging the printed-circuit board or component. Refer to the information in this chapter pertaining to soldering and replacing integrated circuits and transistors.

Repair or replace the defective part. Refer to Chapter 3 and information in this chapter for special removal and replacement procedures. Check for proper operation of the repaired circuit.

Soldering Techniques

Observe the following recommendations when removing or replacing components soldered to a PCB. Poor soldering practices can damage a PCB or heat-sensitive electrical components.

Choosing the proper soldering iron is essential before attempting to remove or replace soldered-in components. Excessive heat is a common cause of damage to a component or PCB. However, transient voltages from solder guns or improperly grounded soldering irons can also damage certain voltage-sensitive semiconductor devices. Refer to

Troubleshooting Static-Sensitive Devices for more specific information.

A 15- to 27-watt pencil-tip soldering iron is recommended to avoid separating the etched circuit wiring from the board material and to avoid damaging active components. A temperature-controlled soldering station rated at 700°F with a fine cone or a very fine chisel tip can also be used.

CAUTION

Solder guns are not recommended for removing or replacing soldered-in components on a printed-circuit board. The added possibility for overheating and the large transient voltage induced by the solder gun could cause damage to heat- or voltage-sensitive devices.

The following additional equipment is recommended for removing and replacing soldered-in components.

- Solder Sucker—Hand-operated vacuum tool used to remove liquified solder from the PCB. Top-of-the-line Soldapull® brand is recommended.
- Solder Wick—Resin-soaked copper braid used for removing excess solder from the lead connections on the PCB. See *Removing Integrated Circuits* for precautions relating to the use of a solder wick on a multi-layer PCB with plated-through holes.
- Flux Remover—Non-corrosive chemical used to clean foreign material from the PCB before soldering, and to remove any flux residue where components have been replaced. Flux remover is also used to clean any foreign material from the PCB during preventive maintenance. Isopropyl alcohol is also recommended as a cleaner.
- Acid Brush—Small stiff-bristled paint or toothbrush used with flux remover to clean flux and other foreign material from the PCB.

Removing Integrated Circuits

The easiest and safest method for removing soldered-in integrated circuits (IC) from a PCB is to cut off each pin as close to the IC case as possible with a tip dyke (diagonal cutter) as shown in Figure 4-1.

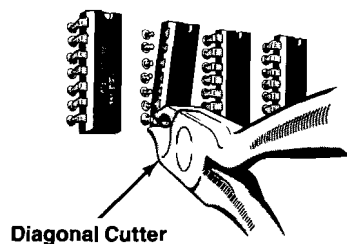

Figure 4-1 Removing IC (Cut Pin Method)

Use the proper soldering iron as previously described under *Soldering Techniques*. Then, to avoid excessive heat buildup in one area of the PCB, apply heat directly to each pin in a random order. Remove the loosened pin with the tip of the soldering iron or with needle-nose pliers as shown in Figure 4-2. Allow a moment for the PCB to cool before proceeding to the next pin. Apply just enough heat to remove any stubborn pins.

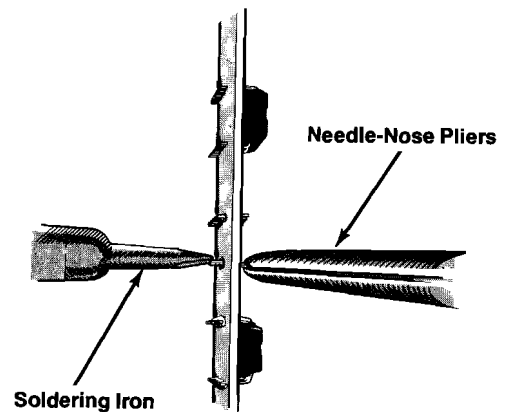

Figure 4-2 Removing IC Pins

For a multi-layer PCB with plated-through holes, use a solder sucker to remove the remaining solder from inside each hole as shown in Figure 4-3. If possible, suck the solder from the opposite side of the PCB from where the heat is applied.

Use a solder wick to remove excess solder from around the lead connection pads on the top and/or bottom surface of the PCB as shown in Figure 4-4.

CAUTION

Do not use a solder wick to remove solder from inside plated-through holes. The heat required for the solder wick to remove the solder from inside the hole could damage the PCB.

Troubleshooting Static-Sensitive Devices

Certain precautions must be taken when working with static-sensitive devices, e.g., microprocessors, field-effect transistors (FET), complementary metal-oxide semiconductors (CMOS), and other large-scale integration (LSI) devices that use metal-oxide semiconductor (MOS) technology. Static charge buildup in a person's body or leakage from an improperly grounded soldering iron can cause static-sensitive device failure.

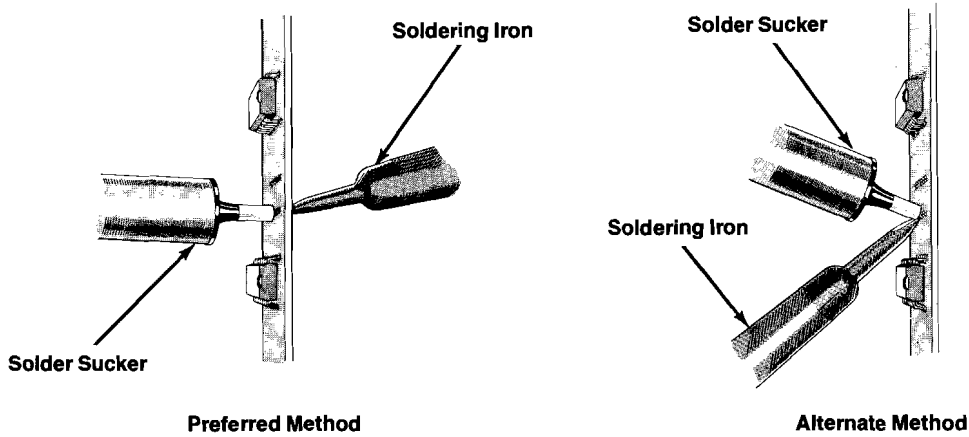

Figure 4-3 Removing Solder from Plated-Through Holes

Before handling a static-sensitive device or a PCB with such devices attached to it, ground any static voltage that may have accumulated in your body by touching an object that has been earth grounded. A bare wire wrapped around your wrist and attached to an earth ground is effective when working extensively with static-sensitive devices. When soldering on a static-sensitive device, use a soldering iron with a properly grounded three-wire cord. (Refer to *Soldering Techniques* for a discussion of recommended soldering irons and procedures.)

A static-sensitive device may appear defective due to leakage on a PCB. Observe the precautions for grounding

static voltages described in the preceding paragraph and clean both sides of the PCB with flux remover or an eraser before replacing what may be a good static-sensitive device. For discrete FET devices, clean thoroughly between the gate, drain, and source leads.

Static-sensitive devices may be packaged in conductive foam or have a protective shorting wire attached to the pins. Remove the conductive foam just prior to inserting the device in its socket or soldering to a PCB. Remove the shorting wire only *after* the device is inserted in its socket or *after* all the leads are soldered in place.

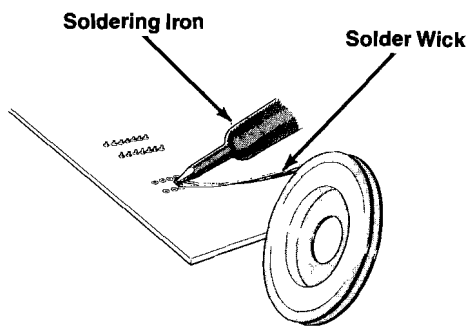

Figure 4-4 Removing Solder from Lead Connection Pads

Illustrated Parts Lists



This chapter provides information you need to order parts for your game. Common hardware (screws, nuts, washers, etc.) has been deleted from most of the parts lists. However, a parts list is included for the hardware to mount the printed-circuit boards (PCBs) to the cabinet.

The PCB parts lists are arranged in alphabetical order by component. Each component subsection is arranged alphanumerically by reference designator.

Other parts lists are arranged alphanumerically by Atari part number. In these parts lists, all A-prefix numbers appear first. Following these are numbers in sequence evaluated up to the hyphen, namely 00- through 99-, then 000598- through approximately 201000-.

When ordering parts, please give the part number, part name, number of this manual, and serial number of your game. This will aid in filling your order rapidly and correctly. We hope the results will be less downtime and more profit from your game.

Atari Customer Service numbers are listed on the inside front cover of this manual.

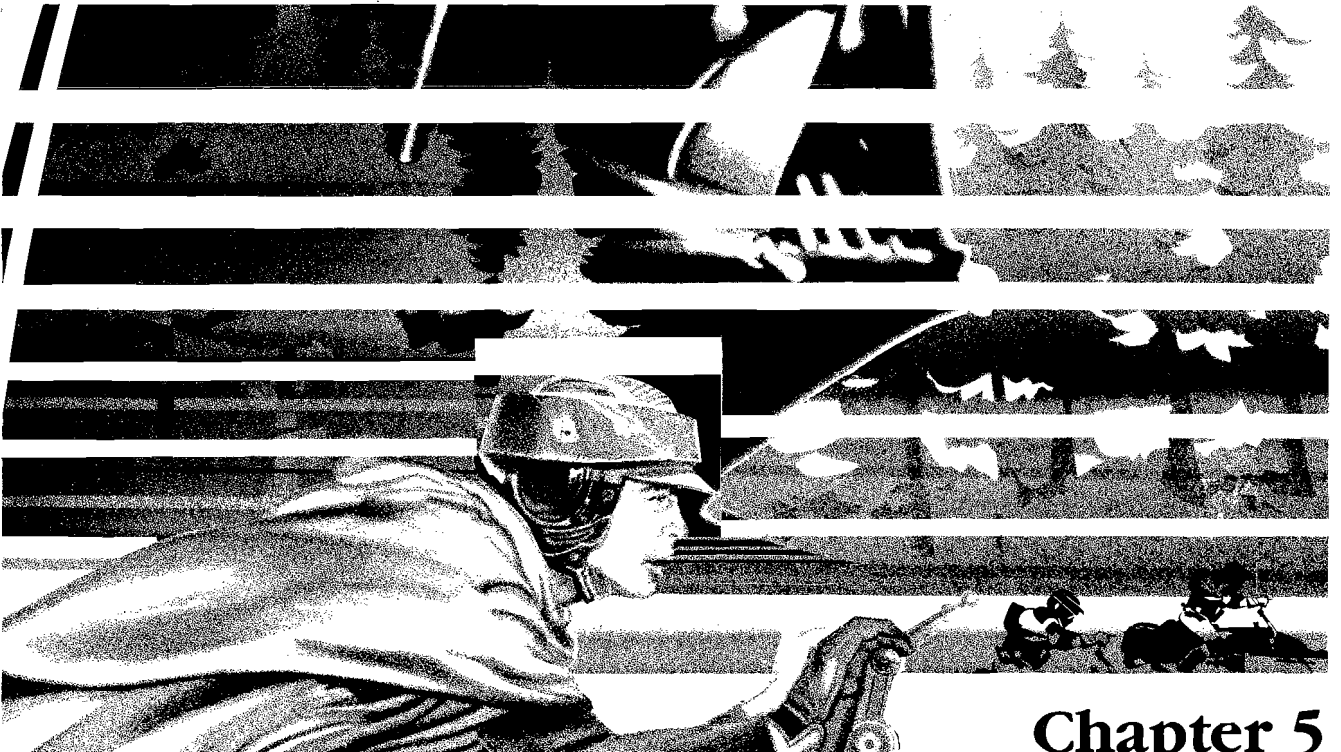

Chapter 5

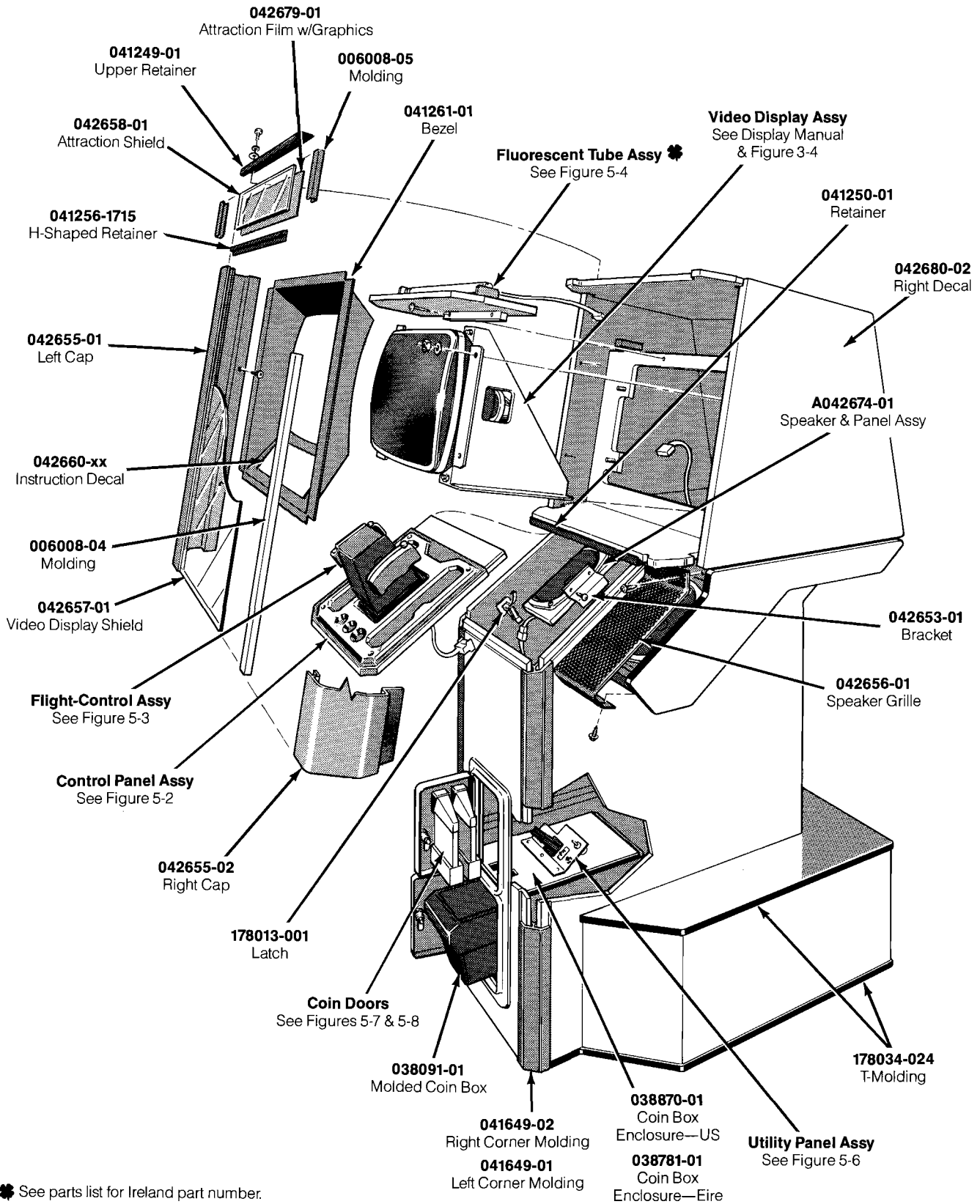

Figure 5-1 Cabinet-Mounted Assemblies
A042641-xx A

Game Documentation—
See following parts list

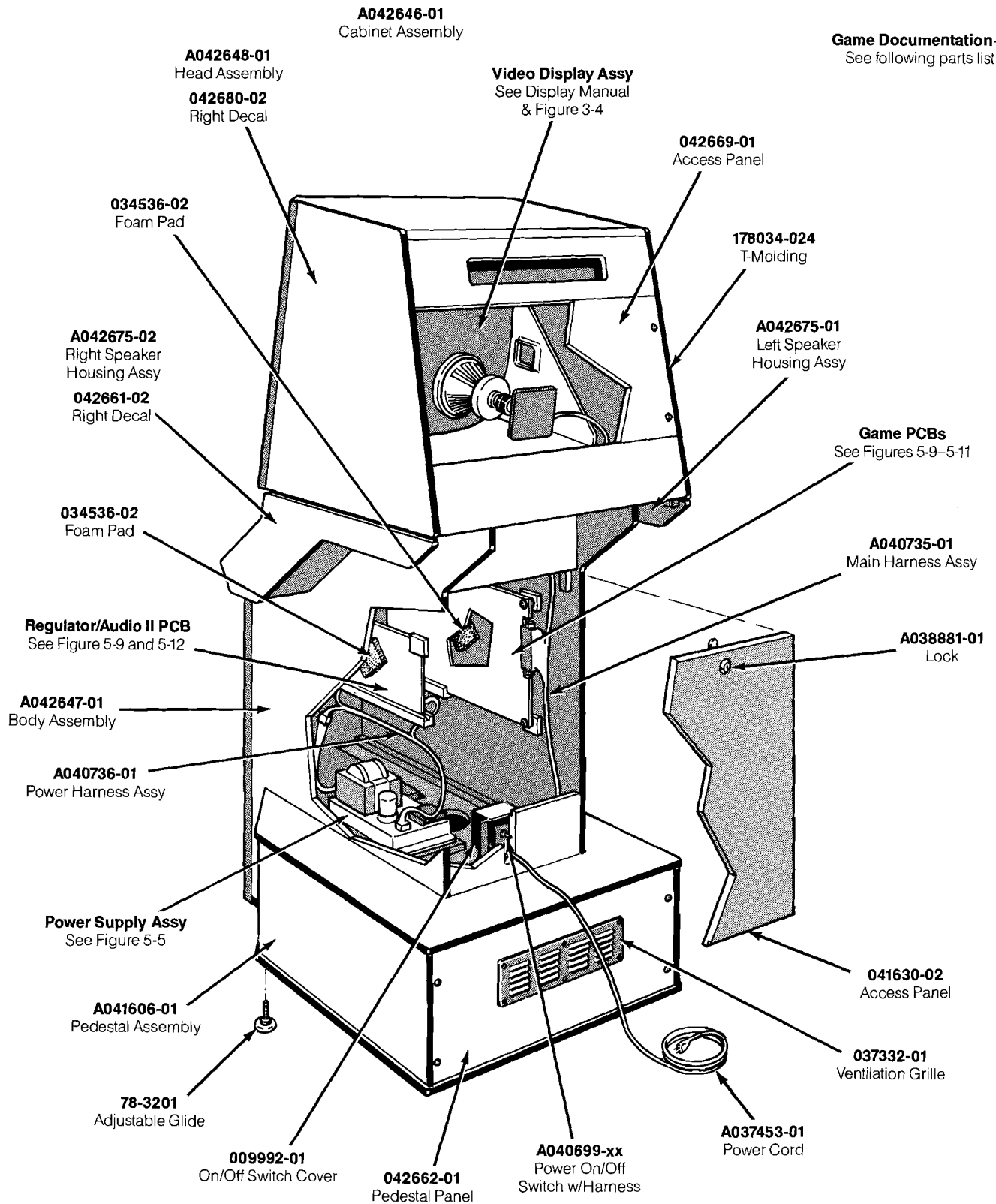

Figure 5-1 Cabinet-Mounted Assemblies, continued
A042641-xx A

Cabinet-Mounted Assemblies Parts List

Part No.	Description
US-Built Cabinet	
A040699-01 038870-01	Power On/Off Switch with Harness Assembly Coin Box Enclosure
Ireland-Built Cabinet	
A039270-01 A040699-04 139016-1007 038781-01	Shorting Plug Assembly (not shown) Power On/Off Switch and Harness Assembly Hantarex 19-Inch Color Raster Display (Acceptable substitute for part no. 139003-1004) Coin Box Enclosure
US- and Ireland-Built Cabinet	
A037453-01 A038881-01 A040735-01 A040736-01	Strain-Relief Power Cord Lock Assembly for Body Access Panel Main Harness Assembly Power Harness Assembly
A042646-01 A041606-01 A042647-01 A042648-01	Cabinet Assembly—includes: Pedestal Assembly Body Assembly Head Assembly
A042674-01 A040738-01 042673-01 148001-013 176015-110	Speaker and Panel Assembly—includes: Speaker Harness Assembly Speaker Panel 6- × 9-Inch, 4 Ohm, 6-Ounce Shielded Speaker #10 × ⅝-Inch Cross-Recessed Pan-Head Screw
A042675-02 A042675-01 78-3201 78-6900402	Right Speaker Housing Assembly Left Speaker Housing Assembly Adjustable Glide ¼-Inch Wide × ⅝-Inch Thick Foam Tape (used between video display and control panel, and attraction shield and retainer—not shown)
<i>The following six items are technical information supplements to this game:</i>	
TM-160 TM-210 TM-220 TM-227 SP-227 ST-227	Electrohome 19-Inch Color Raster Display Manual (use with part no. 92-049) Disco 19-Inch Color Raster Display Manual (use with part no. 139003-1006) Matsushita 19-Inch Color Raster Display Manual (use with part no. 139003-1004) RETURN OF THE JEDI Operators Manual RETURN OF THE JEDI Schematic Package Supplement RETURN OF THE JEDI Chart with Self-Test Procedures and Option Settings
006008-04 006008-05 009992-01 034536-02	Plastic Molding for Display Shield Side Plastic Molding for Attraction Panel On/Off Switch Cover ½-Inch Foam Pad (used on Regulator/Audio II PCB and Main PCB)
037332-01 038091-01 041249-01 041250-01	Ventilation Grille (one not shown—located on top of head assembly) Molded Coin Box Upper Retainer for Attraction Panel Retainer (located between video display and control panel)
041256-1715 041261-01 041630-02 041649-01	H-Shaped Retainer Video Display Bezel Access Panel for Body Assembly Left Corner Molding

(continued on next page)

Cabinet-Mounted Assemblies Parts List, continued

Part No.	Description
041649-02	Right Corner Molding
042653-01	Retaining Bracket
042655-01	Cap for Left Side of Head Assembly
042655-02	Cap for Right Side of Head Assembly
042656-01	Speaker Grille
042657-01	Video Display Shield
042658-01	Glass Attraction Shield
042660-01	English Instruction Decal
042660-02	German Instruction Decal
042661-01	Decal for Left Speaker Housing (not shown)
042661-02	Decal for Right Speaker Housing
042662-01	Pedestal Panel
042669-01	Access Panel for Head Assembly
042679-01	Attraction Film with Graphics
042680-01	Decal for Left Side of Head Assembly (not shown)
042680-02	Decal for Right Side of Head Assembly
176015-112	#10 × ¾-Inch Cross-Recessed Pan-Head Screw (for mounting speakers)
176020-212	#8 × ¾-Inch Black Cross-Recessed Screw (for mounting speaker grille to housing)
178013-001	Spring-Draw Latch
178034-024	¾-Inch T-Molding (21 inches required on front of pedestal base; 168 inches required on side panels of head assembly; 104 inches required on side panels of body assembly; 94 inches required on front panel of body assembly)

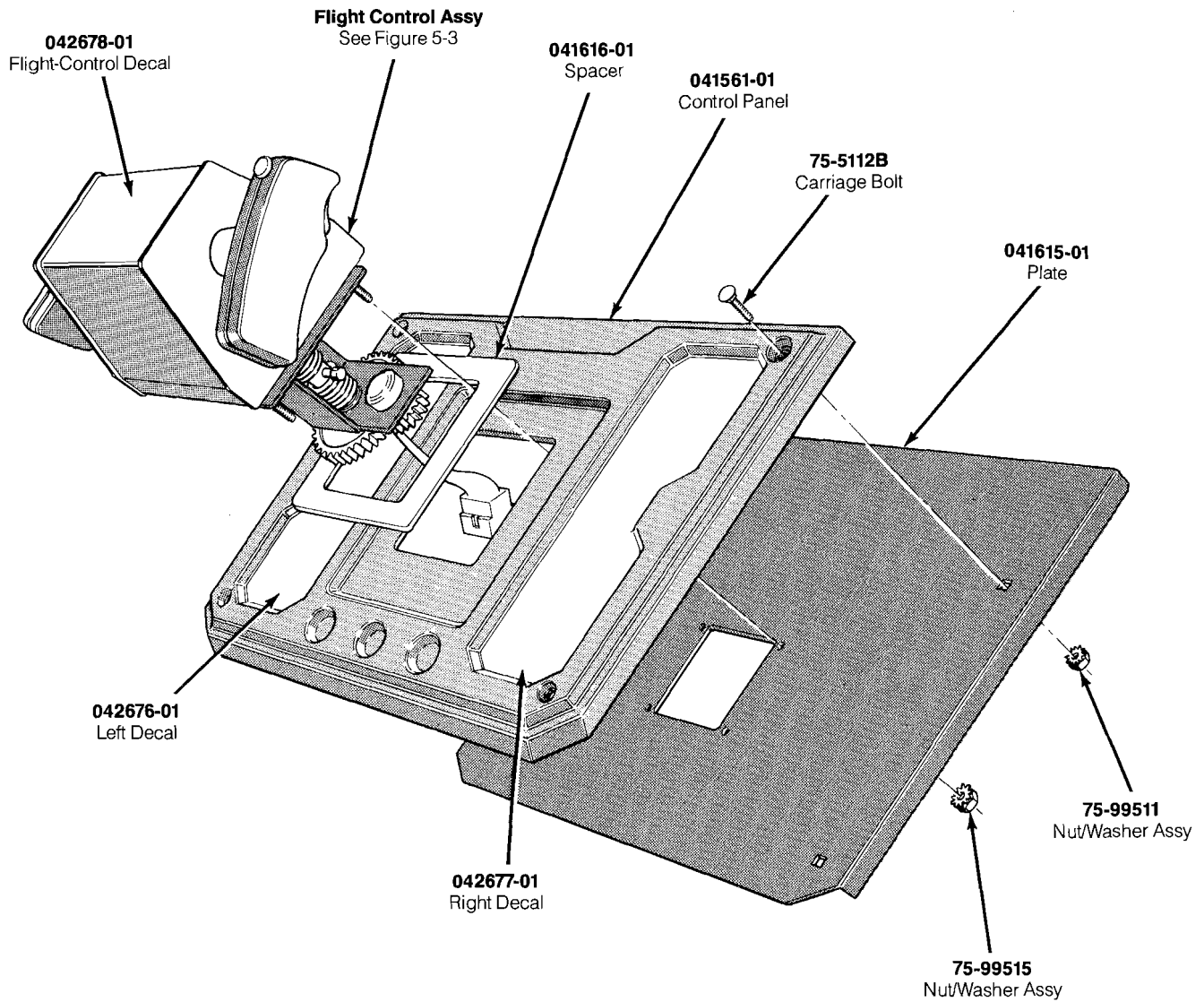

**Figure 5-2 Control Panel Assembly
A042645-xx A
Parts List**

Part No.	Description
041561-01	Formed Control Panel
041615-01	Control-Panel Plate
041616-01	Flight-Control Spacer
042676-01	Left Control Panel Decal
042677-01	Right Control Panel Decal
042678-01	Flight-Control Decal
75-5112B	#10-24 × ¾-Inch Black Carriage Bolt
75-99511	#10-24 Nut/Washer Assembly
75-99515	#¼ -20 Nut/Washer Assembly

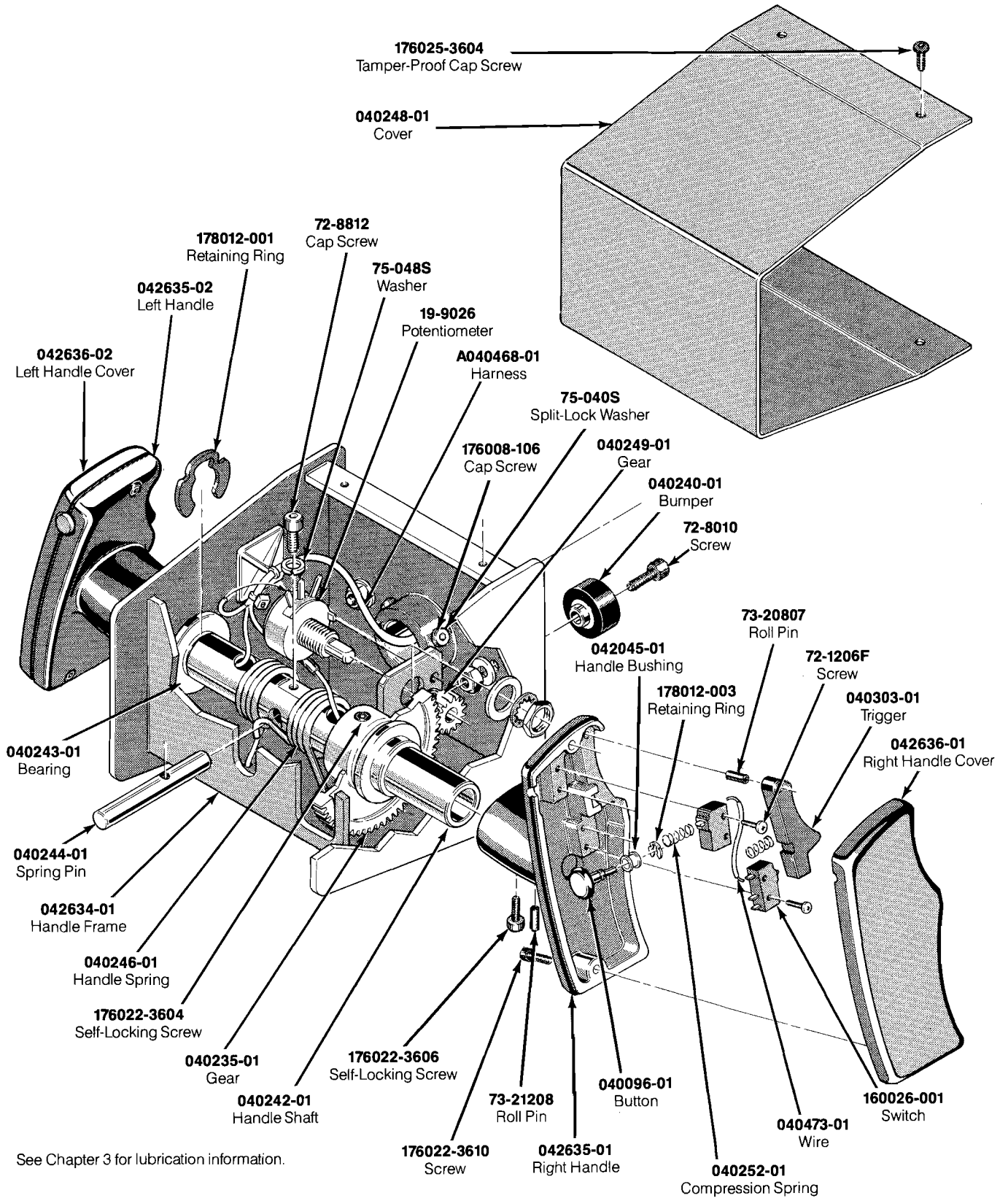

**Figure 5-3 Flight-Control Assembly
A042562-01 A**

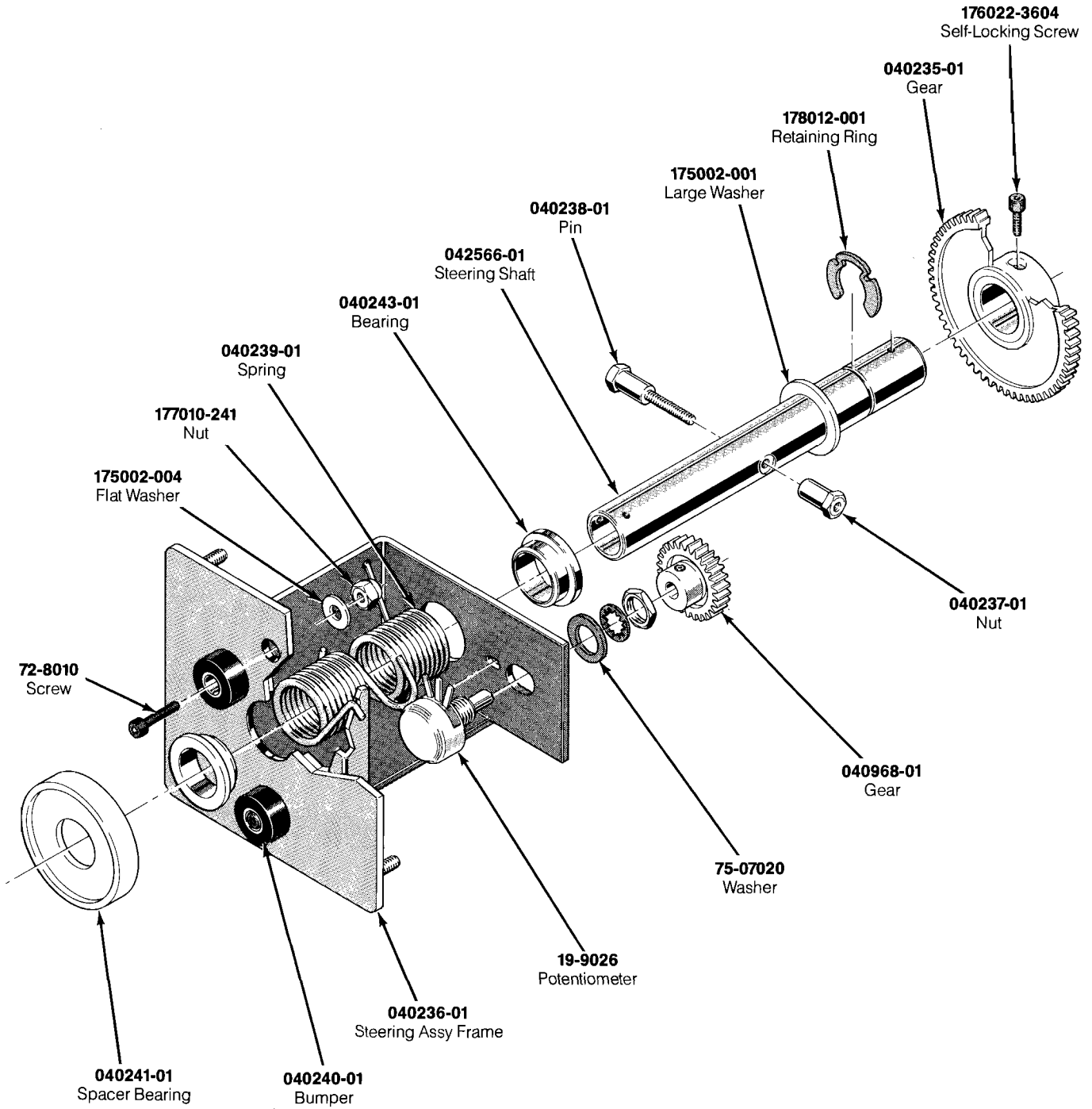
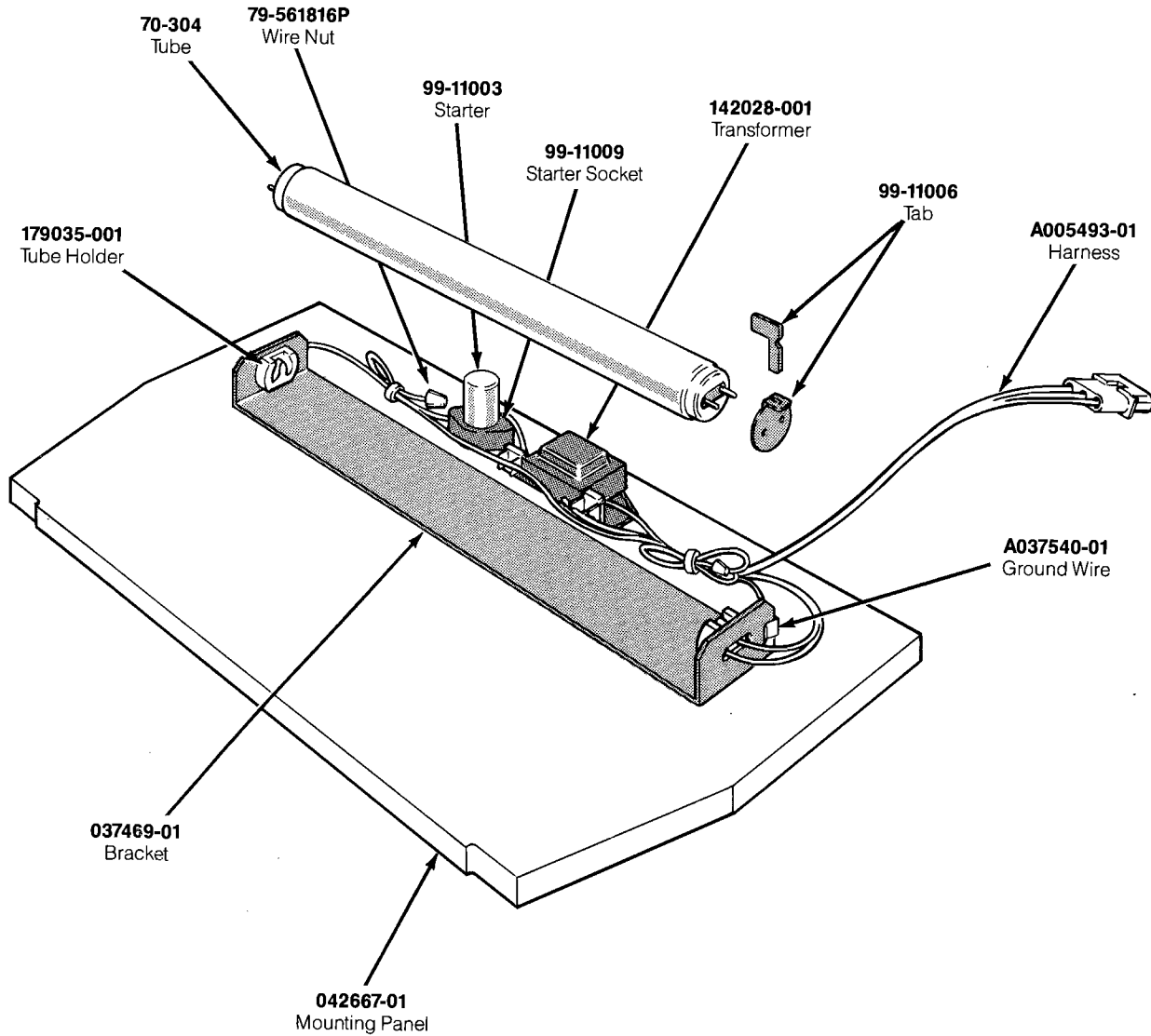

Figure 5-3 Flight-Control Assembly, continued
A042562-01 A

Flight-Control Assembly Parts List

Part No.	Description
A040468-01	Flight Control Harness Assembly
040235-01	60-Tooth Spur Gear
040236-01	Steering Frame
040237-01	Anchor Nut
040238-01	Anchor Pin
040239-01	Steering Torsion Spring
040240-01	Stop Bumper
040241-01	Spacer Bearing
040242-01	Handle Shaft
040243-01	Bearing
040244-01	Spring Pin
040246-01	Handle Torsion Spring
040248-01	Cover
040249-01	14-Tooth Spur Gear
040252-01	Compression Spring
040303-01	Trigger
040473-01	Jumper Wire
040968-01	28-Tooth Spur Gear
042044-01	Button
042045-01	Handle Bushing
042566-01	Steering Shaft
042634-01	Handle Frame
042635-01	Right Handle
042635-02	Left Handle
042636-01	Right Handle Cover
042636-02	Left Handle Cover
160026-001	SPDT Snap Switch
175002-001	0.750-Inch I. D. Large Washer
175002-004	#10 Flat Washer
176008-106	#10-32 × $\frac{3}{8}$ -Inch Self-Locking Socket Head Cap Screw
176022-3604	#6-32 × $\frac{1}{4}$ -Inch Self-Locking Socket-Head Cap Screw
176022-3606	#6-32 × $\frac{3}{8}$ -Inch Self-Locking Socket-Head Cap Screw
176022-3610	#6-32 × $\frac{5}{8}$ -Inch Self-Locking Socket-Head Cap Screw
176025-3604	#6-32 × $\frac{1}{4}$ -Inch Tamper-Proof Button-Head Cap Screw
177010-241	#10-32 Nylock Hex Nut
178012-001	Retaining Ring for 0.750-Inch Diameter Shaft
178012-003	Retaining Ring for $\frac{3}{16}$ -Inch Diameter Shaft
19-9026	5 k Ω Potentiometer
72-1206F	#2-56 × $\frac{3}{8}$ -Inch Cross-Recessed Pan-Head Machine Screw
72-8010	#10-32 × $\frac{3}{8}$ -Inch Socket-Head Cap Screw
72-8812	#8-32 × $\frac{3}{4}$ -Inch Socket-Head Cap Screw
73-20807	$\frac{5}{8}$ -Inch Diameter × $\frac{7}{16}$ -Inch Long Spring Roll Pin
73-21208	$\frac{3}{16}$ -Inch Diameter × $\frac{1}{2}$ -Inch Long Roll Pin
75-07020	0.390-Inch I. D. Flat Washer
75-040S	#10 Split-Lock Washer
75-048S	#8 Split-Lock Washer



NOTE

To make sure the fluorescent tube starts, check that the ground wire is firmly attached to both the ballast transformer and steel tube bracket. For European games, make sure the ground wire is firmly attached to the transformer.

**Figure 5-4 Fluorescent Tube Assembly
US-Built A037458-01 C**

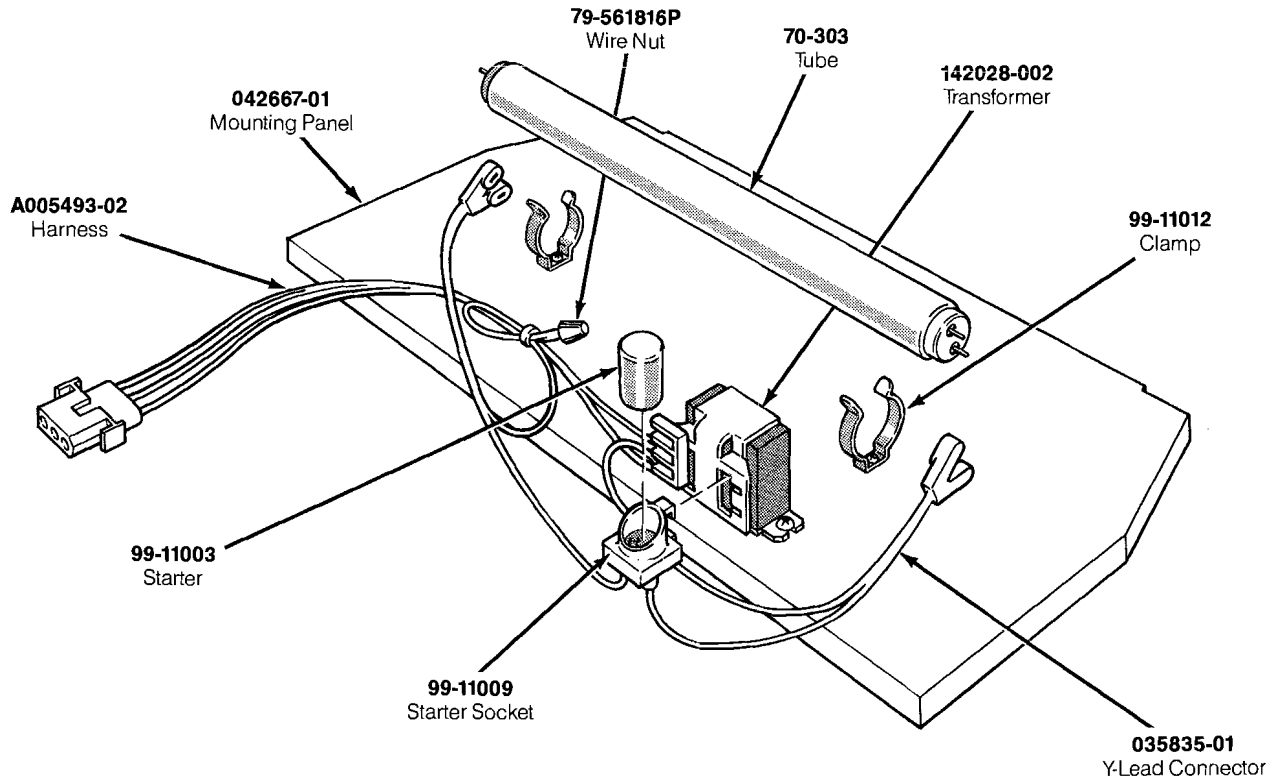

**Figure 5-4 Fluorescent Tube Assembly, continued
Ireland-Built A037458-02 C**

Parts List

Part No.	Description
For US-Built Game	
A005493-01	Fluorescent Light Harness Assembly
A037540-01	Ground Wire with Grounding Clip
037469-01	Tube Bracket
70-304	18-Inch, 15-Watt, Cool White Fluorescent Tube
99-11006	Fluorescent Tube Locking Tab (consists of two pieces)
142028-001	60 Hz, 118 V, Ballast Transformer
179035-001	2-Pin Fluorescent Tube Holder
For Ireland-Built Game	
A005493-02	Fluorescent Light Harness Assembly
035835-01	12-Inch Y-Lead Connector
70-303	18-Inch, 15 Watt, Cool White Fluorescent Tube
99-11012	1 $\frac{3}{16}$ -Inch Clamp
142028-002	50 Hz, 118 V, Ballast Transformer
For US- and Ireland-Built Games	
042667-01	Wood Mounting Panel
79-561816P	Spring-Connector Wire Nut for 16- to 18-Gauge Wires
99-11003	Fluorescent Tube Starter
99-11009	Starter Socket

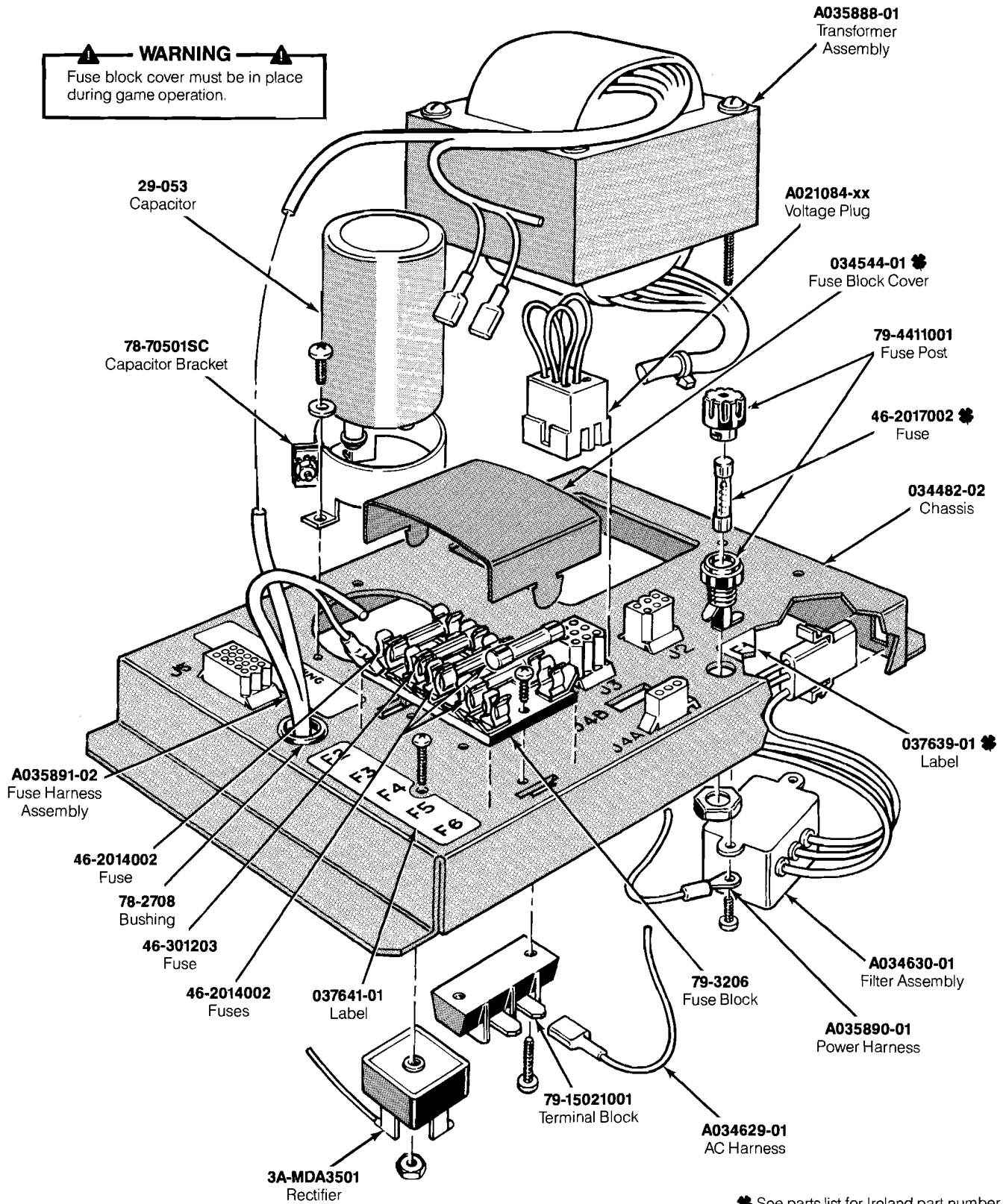

☛ See parts list for Ireland part number.

Figure 5-5 Power Supply Assembly
Ireland-Built A037671-09 J
US-Built A037671-14 J

Power Supply Assembly Parts List

Designator	Description	Part No.
For -09 Version		
F1	Label for Fuse Value	037639-02
F1	4 A, 250 V, 3AG Slow-Blow Glass Cartridge-Type Fuse	46-2014002
J3	Voltage Block Assembly for 220 V (blue wire color) and 240 V (brown wire color)	A037479-02
For -14 Version		
F1	Label for Fuse Value	037639-01
F1	7 A, 250 V Slow-Blow Glass Cartridge-Type Fuse	46-2017002
J3	Voltage Block Assembly for 120 V (yellow wire color)	A021084-02
For -09 and -14 Versions		
C1	27,000 μ F, 15 VDC Electrolytic Capacitor	29-053
C1	2-Inch Diameter Capacitor Mounting Bracket	78-70501SC
CR1	Type-MDA 3501 Bridge Rectifier	3A-MDA3501
F1	Panel-Mounting Non-Indicating 3AG Cartridge-Type Fuse Post	79-4411001
F2-F6	5-Position 3AG Fuse Block with $\frac{1}{4}$ -Inch Quick-Disconnect Terminals	79-3206
F2-F6	Fuse Block Cover	034544-01
F2-F6	Label for Fuse Values	037640-01
F2	4 A, 250 V, 3AG Slow-Blow Glass Cartridge-Type Fuse	46-2014002
F3	20 A, 32 V, 3AG Slow-Blow Glass Cartridge-Type Fuse	46-301203
F4	2-Circuit Single-Row Terminal Block	79-15021001
F4-F6	4 A, 250 V, 3AG Slow-Blow Glass Cartridge-Type Fuse	46-2014002
FL1	RFI Filter Assembly (designation not marked)	A034630-01
J2	Power Harness Assembly	A035890-01
J4A	AC Harness Assembly	A034629-01
T1	Transformer Assembly (Acceptable substitute is part no. A035888-02)	A035888-01
	Power Supply Chassis Base (not shown)	034482-02
	Fuse Harness Assembly	A035891-02
	Nylon Type 6/6 Hole Bushing with $\frac{5}{8}$ -Inch Inside Diameter \times $\frac{5}{64}$ -Inch Outside Diameter \times $\frac{1}{4}$ -Inch Thick	78-2708

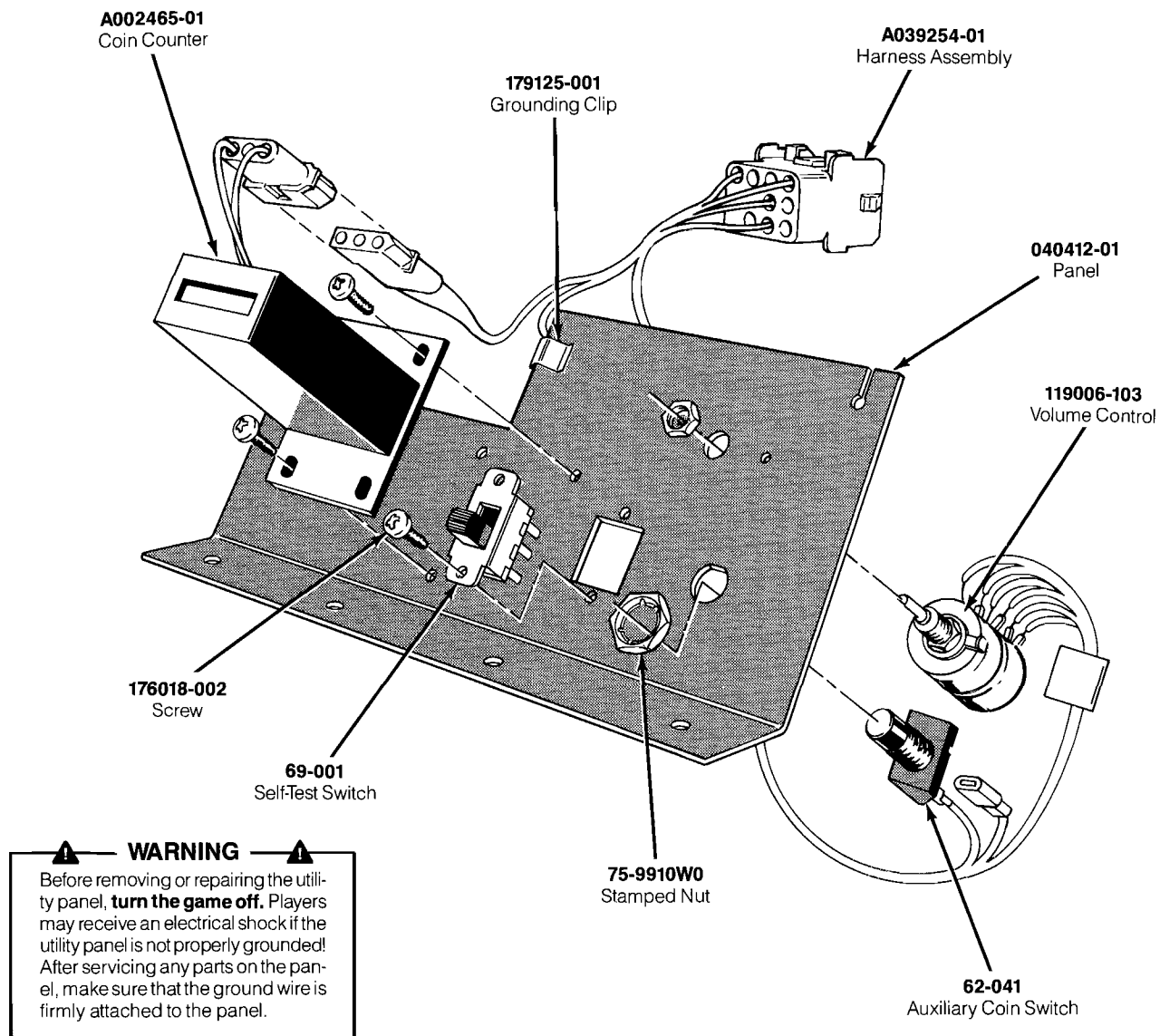

**Figure 5-6 Utility Panel Assembly
A040413-01 C
Parts List**

Part No.	Description
A002465-01	Coin Counter
A039254-01	Volume Control Harness Assembly (includes grounding clip)
040412-01	Component Panel
119006-001	Dual Volume Control
62-041	SPDT Pushbutton Auxiliary Coin Switch with Black Cap
69-001	DPDT Self-Test Switch
75-9910W0	1/8-32 Stamped Nut
176018-002	#6-32 x 1/2-Inch Thread-Forming Machine Screw
179125-001	Grounding Clip

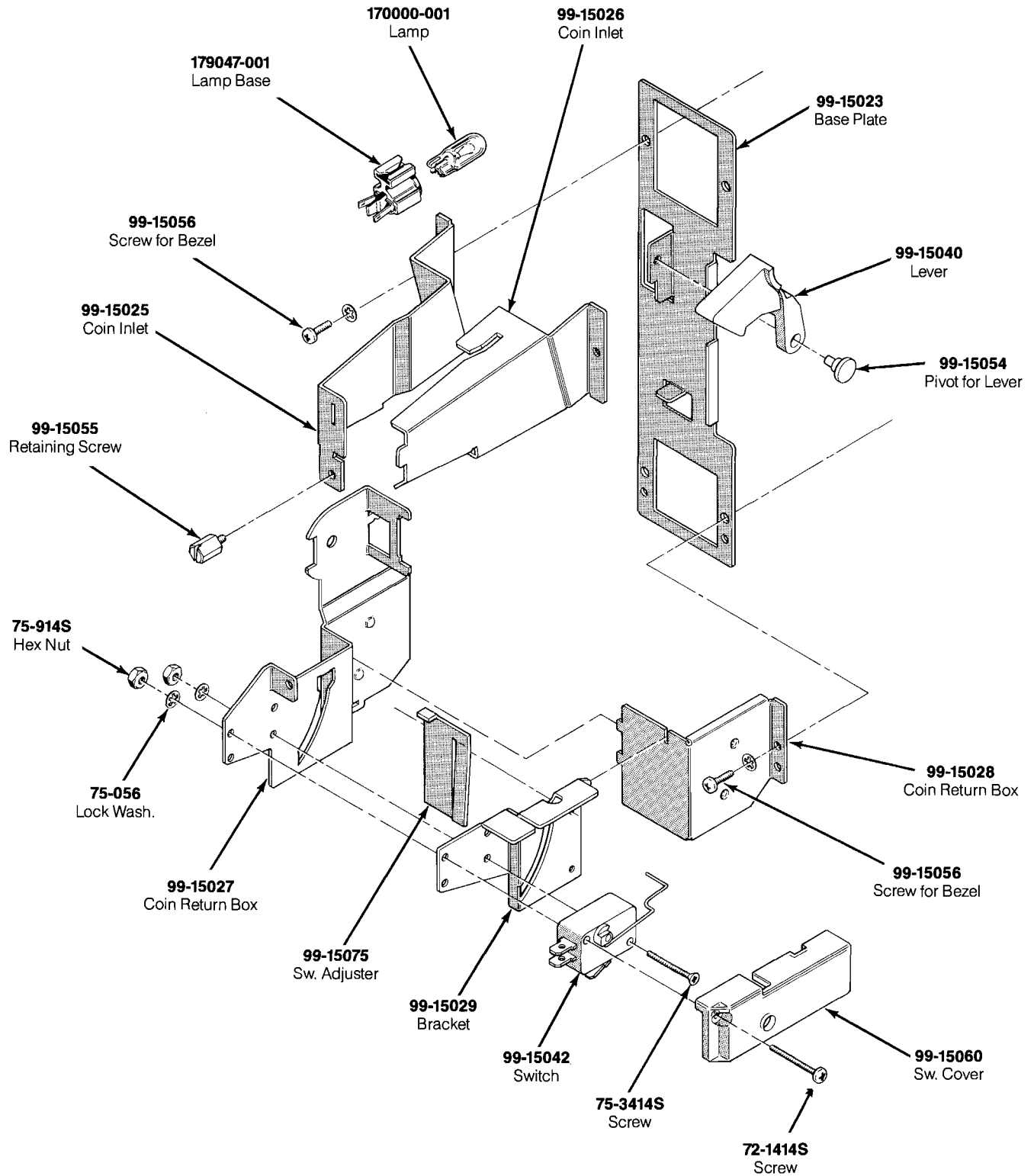

**Figure 5-7 Coin Controls, Inc. Coin-Door Assembly
171034-xxx A**

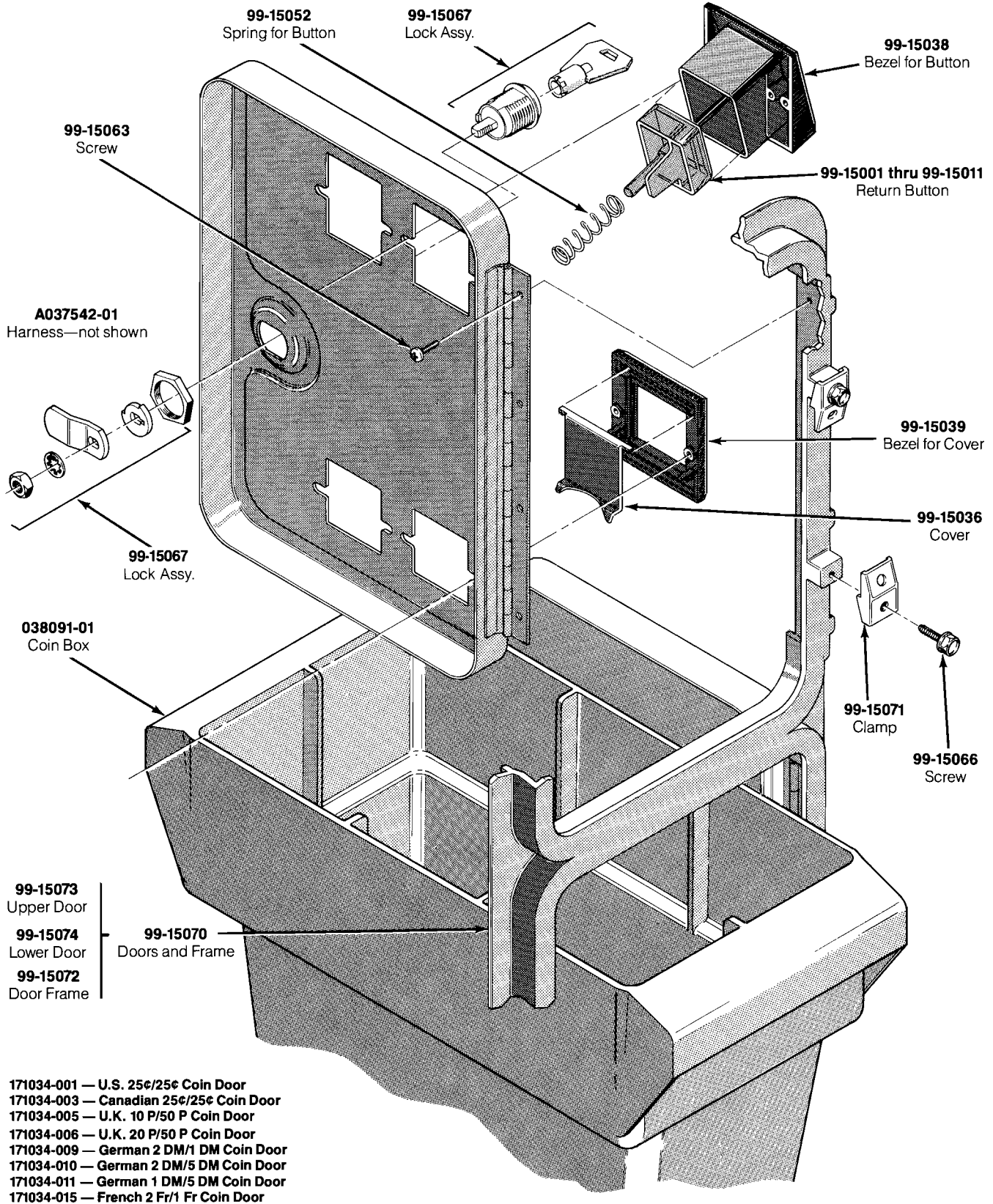
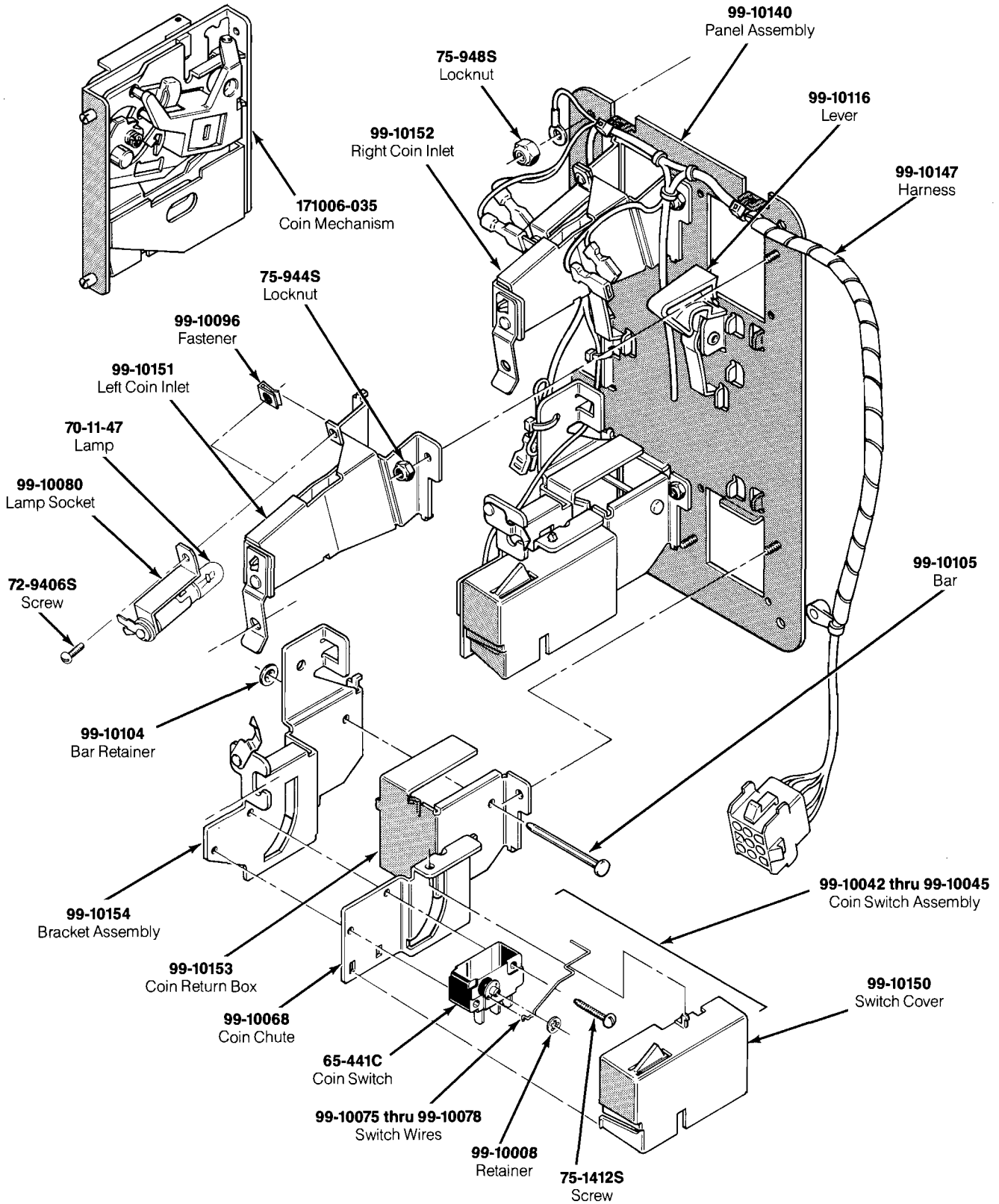

Figure 5-7 Coin Controls, Inc. Coin-Door Assembly, continued
 171034-xxx A

Coin Controls, Inc. Coin Door Assembly Parts List

Part No.	Description
A036597-01	Harness Assembly (Ireland-built cabinet only)
A037542-01	Harness Assembly
72-1414S	#4-40 × 7/8-Inch Cross-Recessed Pan-Head Steel Machine Screw
75-056	#6 Internal-Tooth Zinc-Plated Steel Lock Washer
75-914S	#4-40 Steel Machine Hex Nut
75-3414S	#4-40 × 7/8-Inch 82° Cross-Recessed Flat-Head Steel Machine Screw
99-15001	Coin Return Button with U.S. 25-Cent Price Plate
99-15002	Coin Return Button with U.S. \$1 Price Plate
99-15003	Coin Return Button with German 1 DM Price Plate
99-15004	Coin Return Button with German 2 DM Price Plate
99-15005	Coin Return Button with German 5 DM Price Plate
99-15006	Coin Return Button with Belgian 5 Fr Price Plate
99-15007	Coin Return Button with French 1 Fr Price Plate
99-15008	Coin Return Button with Japanese 100 Yen Price Plate
99-15009	Coin Return Button with British 10 Pence Price Plate
99-15010	Coin Return Button with Australian 20-Cent Price Plate
99-15011	Coin Return Button with Italian 100 Lire Price Plate
99-15025	Left Half of Coin Inlet
99-15026	Right Half of Coin Inlet
99-15027	Side Plate of Coin Return Box
99-15028	Base Plate of Coin Return Box
99-15029	Switch Bracket
99-15036	Metal Coin Return Cover
99-15038	Bezel for Coin Return Button
99-15039	Metal Bezel for Coin Return Button
99-15042	Coin Switch for U.S. 25 Cents
99-15052	Spring for Coin Return Button
99-15055	Retaining Screw
99-15056	#4-40 × 5/16-Inch Cross-Recessed Pan-Head Steel Machine Screw
99-15060	Switch Cover
99-15063	Screw for Hinge
99-15066	Screw for Clamp
99-15067	Lock Assembly
99-15070	Doors and Frame
99-15071	Clamp for Frame
99-15072	Door Frame
99-15073	Upper Door
99-15074	Lower Door
99-15075	Switch Adjuster
99-15083	Base Plate—includes:
99-15040	Lever
99-15054	Pivot for Lever
038091-01	Coin Box—not included in assembly (Acceptable substitute is part no. A037491-01)
170000-001	6.3 V Miniature Wedge-Base Incandescent Lamp
171006-035	Metal Coin Mechanism
171050-001	Dual Entry Face Plate
179047-001	Lamp Base



**Figure 5-8 Coin Acceptors, Inc. Coin-Door Assembly
171027-001 A**

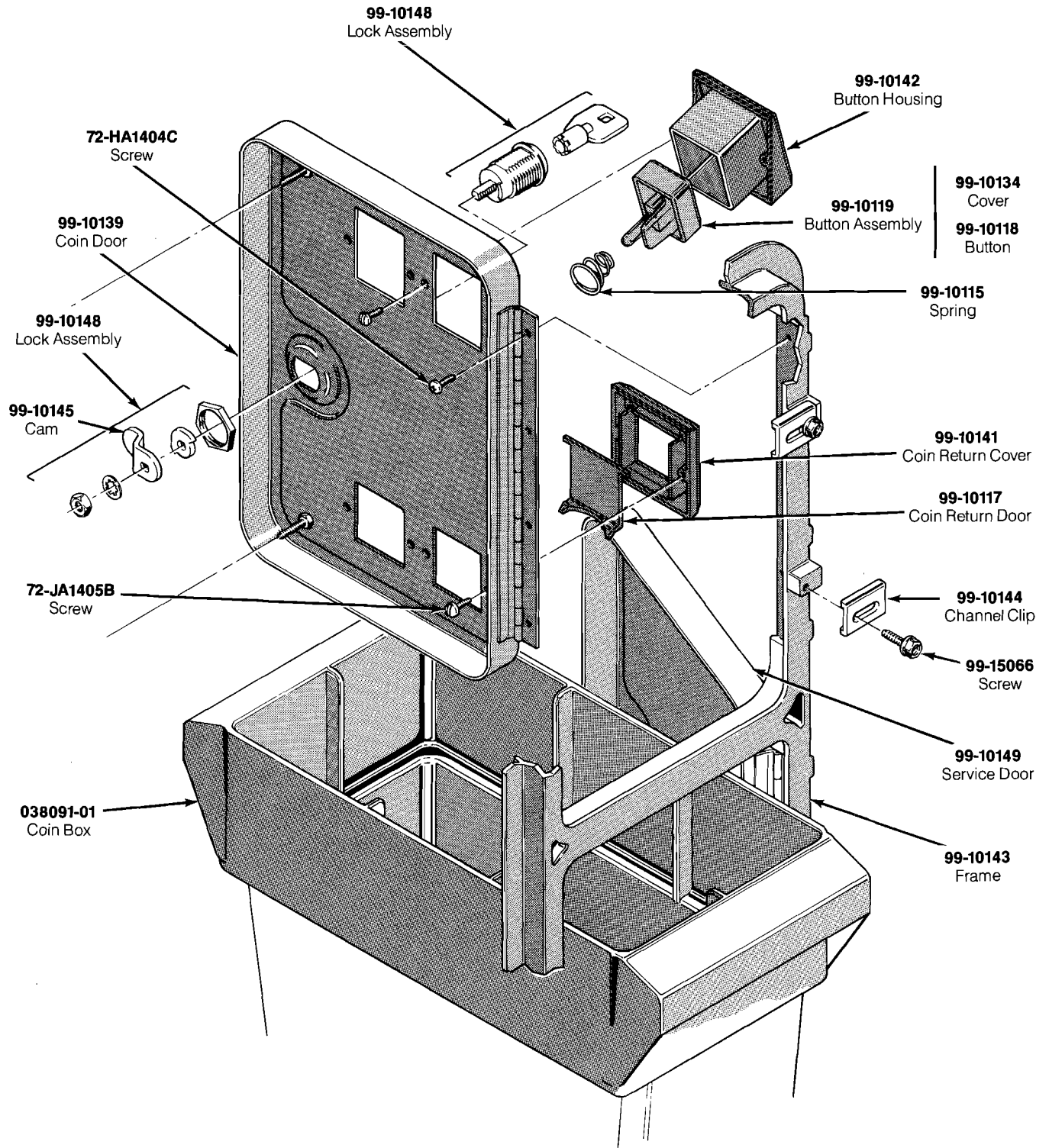

Figure 5-8 Coin Acceptors, Inc. Coin-Door Assembly, continued
171027-001 A

Coin Acceptors, Inc. Coin Door Assembly Parts List

Part No.	Description
65-441C	Coin Switch
70-11-47	Miniature Bayonet Lamp
72-9406S	#4-40 × ⅜-Inch Truss-Head Screw
72-HA1404C	#4-40 × ¼-Inch Pan-Head Screw
72-JA1405B	#4-40 × .31-Inch Pan-Head Screw
75-1412S	#4-40 × ¾-Inch Pan-Head Screw
75-944S	#4-40 Locknut
99-10008	Retainer
99-10042	Coin Switch Assembly for Belgian 5 Fr and U.S. \$.25
99-10043	Coin Switch Assembly for German 1 DM, Japanese 100 Yen, Swiss 1 Fr
99-10044	Coin Switch Assembly for German 2 DM, Italian 100 L, U.S. \$1.00
99-10045	Coin Switch Assembly for Australian \$.20, German 5 DM, British 10 P
99-10068	Coin Return Chute
99-10075	Switch Wire (included in coin switch assembly 99-10043)
99-10076	Switch Wire (included in coin switch assembly 99-10042)
99-10077	Switch Wire (included in coin switch assembly 99-10044)
99-10078	Switch Wire (included in coin switch assembly 99-10045)
99-10080	Lamp Socket
99-10081	Key Holder
99-10096	Fastener
99-10104	Bar Retainer
99-10105	Bar
99-10115	Spring
99-10116	Plastic Coin Return Lever
99-10117	Steel Coin Return Door
99-10118	Amber Coin Return Button
99-10119	Amber Coin Button for U.S. \$.25
99-10134	Coin Button Cover
99-10139	Coin Door
99-10140	Coin Door Inner-Panel Assembly
99-10141	Die-Cast Coin Return Cover
99-10142	Die-Cast Button Housing
99-10143	Coin Door Frame
99-10144	Channel Clip
99-10145	Cam
99-10147	Harness
99-10148	Lock Assembly
99-10149	Service Door
99-10150	Switch Cover
99-10151	Left Coin Inlet
99-10152	Right Coin Inlet
99-10153	Coin Return Box
99-10154	Bracket Assembly
99-15066	Screw for Clamp
038091-01	Coin Box
171006-035	Metal Coin Mechanism for U.S. \$.25
177010-238	#8-32 Hex Locknut

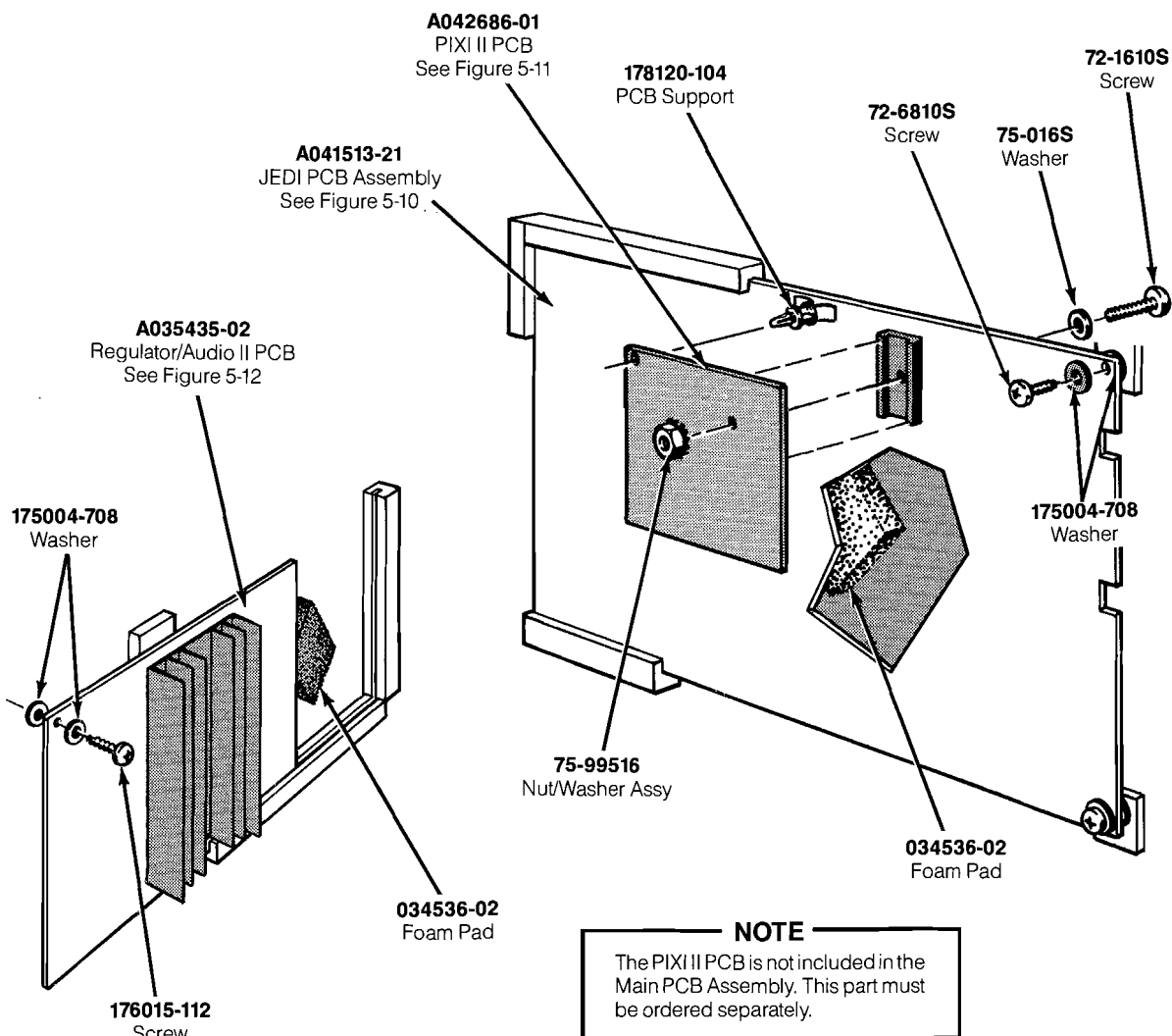

Figure 5-9 Printed-Circuit Board Mounting Hardware
Parts List

Part No.	Description
A035435-02	Regulator/Audio II Printed-Circuit Board Assembly
A041513-21	JEDI Main Printed-Circuit Board Assembly
A042686-01	PIX II Printed-Circuit Board Assembly
72-1610S	#6-32 × 3/8-Inch Cross-Recessed Pan-Head Screw
72-6810S	#8 × 3/8-Inch Cross-Recessed Pan-Head Screw
75-016S	#6 Flat Washer
75-99516	#6-32 Nut/Washer Assembly
034536-02	1/2-Inch Thick Foam Pad
175004-708	#8 Flat Fiber Washer
176015-112	#10 × 3/4-Inch Cross-Recessed Pan-Head Screw
178120-104	1/4-Inch PCB Support

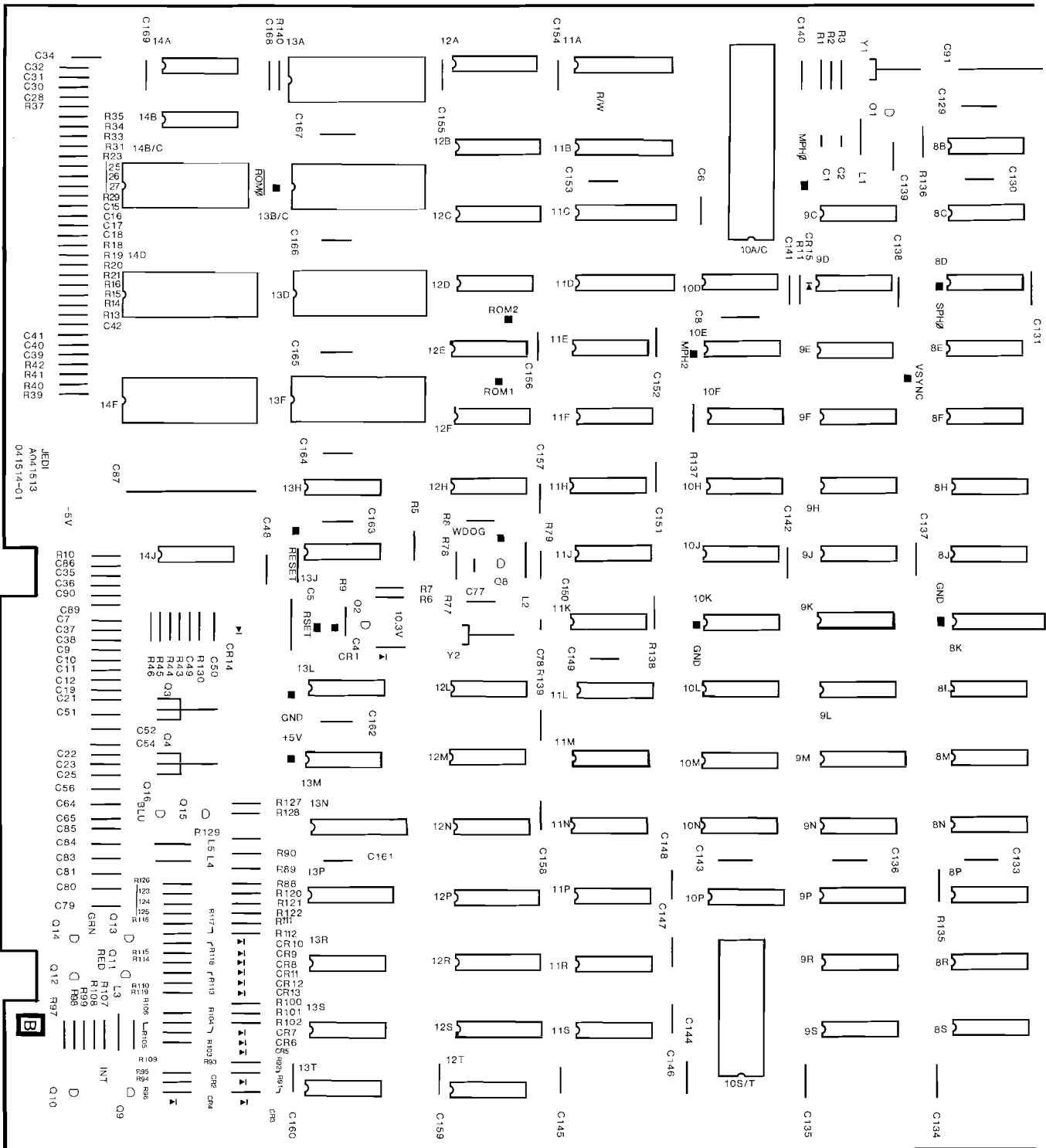

Figure 5-10 Main PCB Assembly
A041513-01 D

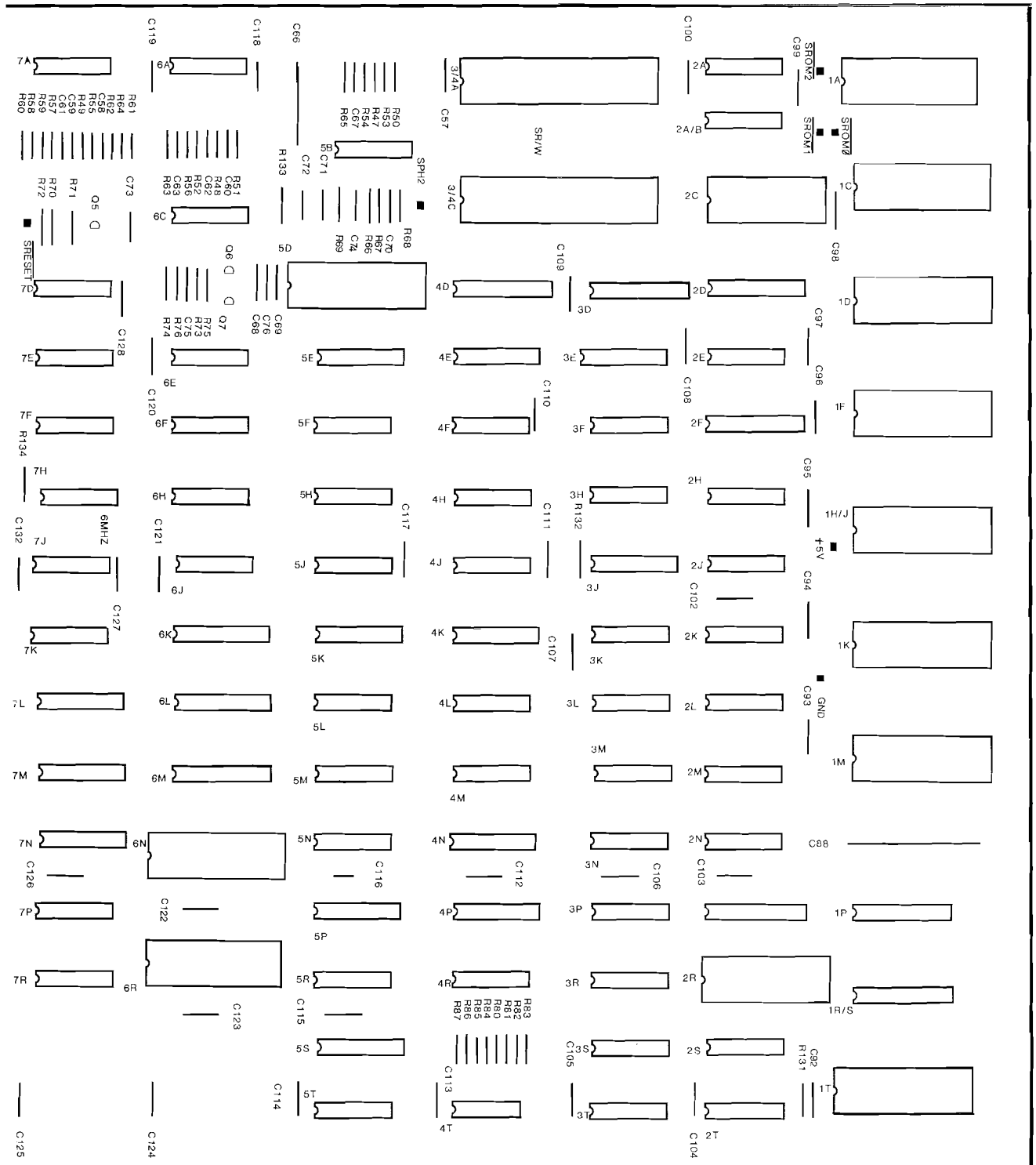

Figure 5-10 Main PCB Assembly, continued
A041513-01 D

Main PCB Assembly Parts List

Designator	Description	Part No.
Capacitors		
C1	100 pF, 100 Mica Capacitor	128002-101
C2	39 pF, 100 Mica Capacitor	128002-102
C4	0.01 μ F, 25 V, Ceramic Capacitor	122005-103
C5	1 μ F, 50 V, Electrolytic Capacitor	24-500105
C6	0.1 μ F, 50 V, Ceramic Capacitor	122002-104
C7	0.01 μ F, 25 V, Ceramic Capacitor	122005-103
C8	0.1 μ F, 50 V, Ceramic Capacitor	122002-104
C9–C12	0.01 μ F, 25 V, Ceramic Capacitor	122005-103
C15–C18	0.1 μ F, 50 V, Ceramic Capacitor	122002-104
C19	0.01 μ F, 25 V, Ceramic Capacitor	122005-103
C21–23	0.01 μ F, 25 V, Ceramic Capacitor	122005-103
C25	0.01 μ F, 25 V, Ceramic Capacitor	122005-103
C28	0.1 μ F, 50 V, Ceramic Capacitor	122002-104
C30–C32	0.1 μ F, 50 V, Ceramic Capacitor	122002-104
C34	0.1 μ F, 50 V, Ceramic Capacitor	122002-104
C35–42	0.01 μ F, 25 V, Ceramic Capacitor	122005-103
C48–C50	0.001 μ F, 50 Ceramic Capacitor	122002-102
C51, 52	0.01 μ F, 25 V, Ceramic Capacitor	122005-103
C54	0.01 μ F, 25 V, Ceramic Capacitor	122005-103
C56–61	0.01 μ F, 25 V, Ceramic Capacitor	122005-103
C62, C63	0.1 μ F, 50 V, Ceramic Capacitor	122002-104
C64, C65	0.01 μ F, 25 V, Ceramic Capacitor	122005-103
C66	100 μ F, 35 V, Electrolytic Capacitor	24-350107
C67	0.1 μ F, 50 V, Ceramic Capacitor	122002-104
C68	0.01 μ F, 25 V, Ceramic Capacitor	122005-103
C69	0.1 μ F, 50 V, Ceramic Capacitor	122002-104
C70	0.01 μ F, 25 V, Ceramic Capacitor	122005-103
C71, C72	0.0027 μ F, 50 V, Ceramic Capacitor	122015-272
C73	0.22 μ F, 25 V, Ceramic Capacitor	122008-224
C74	0.0027 μ F, 50 V, Ceramic Capacitor	122015-272
C75	0.01 μ F, 25 V, Ceramic Capacitor	122005-103
C76	0.1 μ F, 50 V, Ceramic Capacitor	122002-104
C77	100 pF, 100 Mica Capacitor	128002-101
C78	39 pF, 100 Mica Capacitor	128002-102
C79–C81	0.001 μ F, 50 Ceramic Capacitor	122002-102
C83–C85	470 pF, 50 Ceramic Capacitor	122013-471
C86	0.1 μ F, 50 V, Ceramic Capacitor	122002-104
C87, C88	220 μ F, 25 V, Electrolytic Capacitor	24-250227
C89	0.1 μ F, 50 V, Ceramic Capacitor	122002-104
C90	0.1 μ F, 50 V, Ceramic Capacitor	122002-104
C91	100 μ F, 35 V, Electrolytic Capacitor	24-350107
C92–C100	0.1 μ F, 50 V, Ceramic Capacitor	122002-104
C102–C123	0.1 μ F, 50 V, Ceramic Capacitor	122002-104
C126–C133	0.1 μ F, 50 V, Ceramic Capacitor	122002-104
C135–C143	0.1 μ F, 50 V, Ceramic Capacitor	122002-104
C145–C169	0.1 μ F, 50 V, Ceramic Capacitor	122002-104

(continued on next page)

Main PCB Assembly Parts List, continued

Designator	Description	Part No.
Diodes		
CR1	Type-1N756 Diode	32-1N756
CR2-CR13	Type-1N914 Diode	31-1N914
CR14	Type-MV5053 Diode	38-MV5053
CR15	Type 1N100/1N270 Diode	31-1N100
Inductors		
L1, L2	100 μ H Inductor	141002-001
L3-L5	1 μ H Inductor	141007-001
Integrated Circuits		
1A	Type-23128 ROM Integrated Circuit (Acceptable substitute is part number 136030-114)	136030-134
1C	Type-23128 ROM Integrated Circuit (Acceptable substitute is part number 136030-113)	136030-133
1F	Type-23256 ROM Integrated Circuit (Acceptable substitute is part number 136030-111)	136030-131
1H/J	Type-23256 ROM Integrated Circuit (Acceptable substitute is part number 136030-110)	136030-130
1K	Type-23256 ROM Integrated Circuit (Acceptable substitute is part number 136030-109)	136030-129
1M	Type-23256 ROM Integrated Circuit (Acceptable substitute is part number 136030-108)	136030-128
1P	Type-74LS273 Integrated Circuit	37-74LS273
1R/S	Type-74LS273 Integrated Circuit	37-74LS273
1T	Type-2364 ROM Integrated Circuit (Acceptable substitute is part number 136030-115)	136030-135
2A	Type-74LS139 Integrated Circuit	37-74LS139
2A/B	Type-74LS139 Integrated Circuit	37-74LS139
2C	2 k \times 8 RAM Integrated Circuit	137211-001
2D	Type-74LS244 Integrated Circuit	37-74LS244
2E	Type-74LS138 Integrated Circuit	137177-001
2F	Type-74LS273 Integrated Circuit	37-74LS273
2H	Type-74LS194 Integrated Circuit	37-74LS194
2J	Type-74LS194 Integrated Circuit	37-74LS194
2K	Type-74LS158 Integrated Circuit	137203-001
2L	Type-74LS194 Integrated Circuit	37-74LS194
2M	Type-74LS194 Integrated Circuit	37-74LS194
2N	Type-74LS32 Integrated Circuit	37-74LS32
2P	Type-74LS245 Integrated Circuit	37-74LS245
2R	2 k \times 8 RAM Integrated Circuit	137211-001
2S	Type-74LS194 Integrated Circuit	37-74LS194
2T	Type-74LS194 Integrated Circuit	37-74LS194
3D	Type-74LS245 Integrated Circuit	37-74LS245
3E	Type-74LS279 Integrated Circuit	37-74LS279
3F	Type-74LS86 Integrated Circuit	37-74LS86

(continued on next page)

Main PCB Assembly Parts List, continued

Designator	Description	Part No.
3H	Type-74LS175 Integrated Circuit	37-74LS175
3J	Type-74S374 Integrated Circuit	137206-001
3K	Type-74LS21 Integrated Circuit	137210-001
3L	Type-74LS74 Integrated Circuit	37-74LS74
3M	Type-74LS32 Integrated Circuit	37-74LS3
3N	Type-74LS139 Integrated Circuit	37-74LS139
3P	Type-74LS32 Integrated Circuit	37-74LS32
3R	Type-74LS157 Integrated Circuit	37-74LS157
3S	Type-74LS157 Integrated Circuit	37-74LS157
3T	Type-74LS157 Integrated Circuit	37-74LS157
3/4A	Custom Integrated Circuit	137324-1221
3/4C	Type-6502-A Integrated Circuit	90-6013
4D	Type-74LS273 Integrated Circuit	37-74LS273
4E	Type-74LS374 Integrated Circuit	37-74LS374
4F	Type-74S08 Integrated Circuit	37-74S08
4H	Type-74LS283 Integrated Circuit	137204-001
4J	Type-74S157 Integrated Circuit	37-74S157
4K	Type-2149H-2 Integrated Circuit	137199-002
4L	Type-74LS163A Integrated Circuit	37-74LS163A
4M	Type-74LS163A Integrated Circuit	37-74LS163A
4N	Type-74LS163A Integrated Circuit	37-74LS163A
4P	Type-2149H-2 Integrated Circuit	137199-002
4R	Type-74LS257 Integrated Circuit	37-74LS257
4T	Type-74LS04 Integrated Circuit	37-74S04
5B	Type-LM324 Integrated Circuit	37-LM324
5D	Type TMS-5220 Integrated Circuit	137308-001
5E	Type-74LS374 Integrated Circuit	37-74LS374
5F	Type-74LS00 Integrated Circuit	37-74LS00
5H	Type-74LS283 Integrated Circuit	137204-001
5J	Type-74S157 Integrated Circuit	37-74S157
5K	Type-2149H-2 Integrated Circuit	137199-002
5L	Type-74LS163A Integrated Circuit	37-74LS163A
5M	Type-74LS163A Integrated Circuit	37-74LS163A
5N	Type-74LS163A Integrated Circuit	37-74LS163A
5P	Type-2149H-2 Integrated Circuit	137199-002
5R	Type-74LS257 Integrated Circuit	37-74LS257
5S	Type-74S374 Integrated Circuit	137206-001
5T	Type-74LS298 Integrated Circuit	137201-001
6A	Type-LM324 Integrated Circuit	37-LM324
6C	Type-74LS163A Integrated Circuit	37-74LS163A
6E	Type-74LS257 Integrated Circuit	37-74LS257
6F	Type-74LS74 Integrated Circuit	37-74LS74
6H	Type-74S74 Integrated Circuit	37-74S74
6J	Type-74LS174 Integrated Circuit	37-74LS174

(continued on next page)

Main PCB Assembly Parts List, continued

Designator	Description	Part No.
6K	Type-74LS245 Integrated Circuit	37-74LS245
6L	Type-74LS245 Integrated Circuit	37-74LS245
6M	Type-74LS273 Integrated Circuit	37-74LS273
6N	Type-23256 ROM Integrated Circuit (Acceptable substitute is part number 136030-107)	136030-127
6R	Type-23256 ROM Integrated Circuit (Acceptable substitute is part number 136030-106)	136030-126
7A	Type-LM324 Integrated Circuit	37-LM324
7D	Type-74C04 Integrated Circuit	137309-001
7E	Type-74LS04 Integrated Circuit	37-74LS04
7F	Type-74LS32 Integrated Circuit	37-74LS32
7H	Type-74LS174 Integrated Circuit	37-74LS174
7J	Type-74LS32 Integrated Circuit	37-74LS32
7K	Type-74LS00 Integrated Circuit	37-74LS00
7L	Type-2114-2 Integrated Circuit	90-7036
7M	Type-2114-2 Integrated Circuit	90-7036
7N	Type-2114-2 Integrated Circuit	90-7036
7P	Type-74LS194 Integrated Circuit	37-74LS194
7R	Type-74LS194 Integrated Circuit	37-74LS194
8B	Type-74LS74 Integrated Circuit	37-74LS74
8C	Type-74S74 Integrated Circuit	37-74S74
8D	Type-74LS32 Integrated Circuit	37-74LS32
8E	Type-74LS74 Integrated Circuit	37-74LS74
8F	Type-74LS86 Integrated Circuit	37-74LS86
8H	Type-74LS139 Integrated Circuit	37-74LS139
8J	Type-74LS283 Integrated Circuit	137204-001
8K	Type-74LS273 Integrated Circuit	37-74LS273
8L	Type-74LS157 Integrated Circuit	37-74LS157
8M	Type-74LS157 Integrated Circuit	37-74LS157
8N	Type-74LS157 Integrated Circuit	37-74LS157
8P	Type-74LS194 Integrated Circuit	37-74LS194
8R	Type-74LS194 Integrated Circuit	37-74LS194
8S	Type-74LS163A Integrated Circuit	37-74LS163A
9C	Type-74S112 Integrated Circuit	137223-001
9D	Type-74S74 Integrated Circuit	37-74S74
9E	Type-74LS10 Integrated Circuit	37-74LS10
9H	Type-82S129 Integrated Circuit	136030-116
9J	Type-74LS163A Integrated Circuit	37-74LS163A
9K	Type-74S86 Integrated Circuit	37-74LS74
9L	Type-74LS283 Integrated Circuit	137204-001
9M	Type-74LS273 Integrated Circuit	37-74LS273
9N	Type-74LS283 Integrated Circuit	137204-001
9P	Type-74LS245 Integrated Circuit	37-74LS245
9R	Type-74LS158 Integrated Circuit	137203-001
9S	Type-74S189 Integrated Circuit	37-74S189
9F	Type-74LS175 Integrated Circuit	37-74LS175

(continued on next page)

Main PCB Assembly Parts List, continued

Designator	Description	Part No.
10A/C	Type-6502-B Integrated Circuit	90-6012
10D	Type-74LS74 Integrated Circuit	37-74LS74
10E	Type-74LS74 Integrated Circuit	37-74LS74
10F	Type-74LS138 Integrated Circuit	137177-001
10H	Type-74LS163A Integrated Circuit	37-74LS163A
10J	Type-74LS32 Integrated Circuit	37-74LS3
10K	Type-74LS74 Integrated Circuit	37-74LS74
10L	Type-74LS08 Integrated Circuit	37-74LS08
10M	Type-74S32 Integrated Circuit	37-74S32
10P	Type-74LS175 Integrated Circuit	37-74LS175
11A	Type-74S244 Integrated Circuit	137333-001
11B	Type-74S244 Integrated Circuit	137333-001
11C	Type-74LS245 Integrated Circuit	37-74LS245
11D	Type-74LS245 Integrated Circuit	37-74LS245
11E	Type-74LS08 Integrated Circuit	37-74LS08
11F	Type-74LS138 Integrated Circuit	137177-001
11H	Type-74S04 Integrated Circuit	37-74S04
11J	Type-74S163 Integrated Circuit	137274-001
11K	Type-74S74 Integrated Circuit	37-74S74
11L	Type-74LS163A Integrated Circuit	37-74LS163A
11M	Type-74LS20 Integrated Circuit	37-74LS20
11N	Type-74LS00 Integrated Circuit	37-74LS00
11P	Type-74S157 Integrated Circuit	37-74S157
11R	Type-74S157 Integrated Circuit	37-74S157
11S	Type-74S157 Integrated Circuit	37-74S157
12A	Type-74LS175 Integrated Circuit	37-74LS175
12B, 12C	Type-X2212-30 Integrated Circuit	137288-001
12D	Type-74LS138 Integrated Circuit	137177-001
12E	Type-74LS08 Integrated Circuit	37-74LS08
12F	Type-74LS138 Integrated Circuit	137177-001
12H	Type-74LS00 Integrated Circuit	37-74LS00
12L	Type-74LS74 Integrated Circuit	37-74LS74
12M	Type-74LS74 Integrated Circuit	37-74LS74
12N	Type-74S32 Integrated Circuit	37-74S32
12P	Type-2149H-3 Integrated Circuit	137199-001
12R	Type-2149H-3 Integrated Circuit	137199-001
12S	Type-2149H-3 Integrated Circuit	137199-001
12T	Type-7406 Integrated Circuit	37-7406
13A	Type-23128 ROM Integrated Circuit (Acceptable substitute is part number 136030-105)	136030-125
13B/C	Type-23128 ROM Integrated Circuit (Acceptable substitute is part number 136030-104)	136030-124

(continued on next page)

Main PCB Assembly Parts List, continued

Designator	Description	Part No.
13D	Type-23128 ROM Integrated Circuit (Acceptable substitute is part number 136030-103)	136030-123
13F	Type-23128 ROM Integrated Circuit (Acceptable substitute is part number 136030-102)	136030-122
13H	Type-74LS90 Integrated Circuit	37-74LS90
13J	Type-74LS14 Integrated Circuit	37-74LS14
13L	Type-74LS74 Integrated Circuit	37-74LS74
13M	Type-74S32 Integrated Circuit	37-74S32
13N	Type-74LS245 Integrated Circuit	37-74LS245
13P	Type-74LS245 Integrated Circuit	37-74LS245
13R	Type-74LS174 Integrated Circuit	37-74LS174
13S	Type-74LS174 Integrated Circuit	37-74LS174
13T	Type-74LS27 Integrated Circuit	37-74LS27
14A	Type-74LS257 Integrated Circuit	37-74LS257
14B	Type-74LS257 Integrated Circuit	37-74LS257
14B/C	2 k × 8 RAM Integrated Circuit	137211-001
14D	Type-ADC-0809 Integrated Circuit	137243-001
14F	Type-23128 ROM Integrated Circuit (Acceptable substitute is part number 136030-101)	136030-121
14J	Type-74LS259 Integrated Circuit	37-74LS259
Transistors		
Q1, Q2	Type-2N3904 Transistor	34-2N3904
Q3, Q4	Type-2N6044 Transistor	34-2N6044
Q5, Q6	Type-2N3906 Transistor	33-2N3906
Q7	Type-2N3904 Transistor	34-2N3904
Q8	Type-2N3904 Transistor	34-2N3904
Q9	Type-2N3906 Transistor	33-2N3906
Q10	Type-2N3904 Transistor	34-2N3904
Q11	Type-2N3906 Transistor	33-2N3906
Q12	Type-2N3904 Transistor	34-2N3904
Q13	Type-2N3906 Transistor	33-2N3906
Q14	Type-2N3904 Transistor	34-2N3904
Q15	Type-2N3906 Transistor	33-2N3906
Q16	Type-2N3904 Transistor	34-2N3904
Resistors		
R1	10 k Ω , \pm 5%, 1/4 W Resistor	110000-103
R2	10 k Ω , \pm 5%, 1/4 W Resistor	110000-103
R3	220 Ω , \pm 5%, 1/4 W Resistor	110000-221
R5	4.7 k Ω , \pm 5%, 1/4 W Resistor	110000-472
R6	1 k Ω , \pm 5%, 1/4 W Resistor	110000-102
R7	220 Ω , \pm 5%, 1/4 W Resistor	110000-221
R8	1 k Ω , \pm 5%, 1/4 W Resistor	110000-102
R9	10 k Ω , \pm 5%, 1/4 W Resistor	110000-103

(continued on next page)

Main PCB Assembly Parts List, continued

Designator	Description	Part No.
R10	1 k Ω , $\pm 5\%$, 1/4 W Resistor	110000-102
R11	10 k Ω , $\pm 5\%$, 1/4 W Resistor	110000-103
R13-R16	470 Ω , $\pm 5\%$, 1/4 W Resistor	110000-471
R18-R21	1 k Ω , $\pm 5\%$, 1/4 W Resistor	110000-102
R23	470 Ω , $\pm 5\%$, 1/4 W Resistor	110000-471
R25-R27	470 Ω , $\pm 5\%$, 1/4 W Resistor	110000-471
R29	470 Ω , $\pm 5\%$, 1/4 W Resistor	110000-471
R31	1 k Ω , $\pm 5\%$, 1/4 W Resistor	110000-102
R33-R35	1 k Ω , $\pm 5\%$, 1/4 W Resistor	110000-102
R37	1 k Ω , $\pm 5\%$, 1/4 W Resistor	110000-102
R39-R42	1 k Ω , $\pm 5\%$, 1/4 W Resistor	110000-102
R43	220 Ω , $\pm 5\%$, 1/4 W Resistor	110000-221
R44	220 Ω , $\pm 5\%$, 1/4 W Resistor	110000-221
R45-R47	1 k Ω , $\pm 5\%$, 1/4 W Resistor	110000-102
R48	39 k Ω , $\pm 5\%$, 1/4 W Resistor	110000-393
R49	39 k Ω , $\pm 5\%$, 1/4 W Resistor	110000-393
R50	1 k Ω , $\pm 5\%$, 1/4 W Resistor	110000-102
R51	15 k Ω , $\pm 5\%$, 1/4 W Resistor	110000-153
R52	15 k Ω , $\pm 5\%$, 1/4 W Resistor	110000-153
R53	1 k Ω , $\pm 5\%$, 1/4 W Resistor	110000-102
R54	1 k Ω , $\pm 5\%$, 1/4 W Resistor	110000-102
R55	100 k Ω , $\pm 5\%$, 1/4 W Resistor	110000-104
R56	100 k Ω , $\pm 5\%$, 1/4 W Resistor	110000-104
R57	22 k Ω , $\pm 5\%$, 1/4 W Resistor	110000-223
R58	100 k Ω , $\pm 5\%$, 1/4 W Resistor	110000-104
R59	91 k Ω , $\pm 5\%$, 1/4 W Resistor	110000-913
R60	100 k Ω , $\pm 5\%$, 1/4 W Resistor	110000-104
R61	22 k Ω , $\pm 5\%$, 1/4 W Resistor	110000-223
R62	100 k Ω , $\pm 5\%$, 1/4 W Resistor	110000-104
R63	100 k Ω , $\pm 5\%$, 1/4 W Resistor	110000-104
R64	91 k Ω , $\pm 5\%$, 1/4 W Resistor	110000-913
R65	10 k Ω , $\pm 5\%$, 1/4 W Resistor	110000-103
R66	1.8 k Ω , $\pm 5\%$, 1/4 W Resistor	110000-102
R67	100 k Ω , $\pm 5\%$, 1/4 W Resistor	110000-104
R68	12 k Ω , $\pm 5\%$, 1/4 W Resistor	110000-123
R69	12 k Ω , $\pm 5\%$, 1/4 W Resistor	110000-123
R70	10 k Ω , $\pm 5\%$, 1/4 W Resistor	110000-103
R71	3.3 k Ω , $\pm 5\%$, 1/4 W Resistor	110000-332
R72	1 k Ω , $\pm 5\%$, 1/4 W Resistor	110000-102
R73	10 k Ω , $\pm 5\%$, 1/4 W Resistor	110000-103
R74	3.3 k Ω , $\pm 5\%$, 1/4 W Resistor	110000-332
R75	1 k Ω , $\pm 5\%$, 1/4 W Resistor	110000-102
R76	3.3 k Ω , $\pm 5\%$, 1/4 W Resistor	110000-332
R77	10 k Ω , $\pm 5\%$, 1/4 W Resistor	110000-103

(continued on next page)

Main PCB Assembly Parts List, continued

Designator	Description	Part No.
R78	10 k Ω , $\pm 5\%$, 1/4 W Resistor	110000-103
R79	220 Ω , $\pm 5\%$, 1/4 W Resistor	110000-221
R80-R87	1 k Ω , $\pm 5\%$, 1/4 W Resistor	110000-102
R88-R90	220 Ω , $\pm 5\%$, 1/4 W Resistor	110000-221
R91-R93	1 k Ω , $\pm 5\%$, 1/4 W Resistor	110000-102
R94	4.7 k Ω , $\pm 5\%$, 1/4 W Resistor	110000-472
R95	10 k Ω , $\pm 5\%$, 1/4 W Resistor	110000-103
R96	22 k Ω , $\pm 5\%$, 1/4 W Resistor	110000-223
R97	15 k Ω , $\pm 5\%$, 1/4 W Resistor	110000-153
R98	1 k Ω , $\pm 5\%$, 1/4 W Resistor	110000-102
R99	82 Ω , $\pm 5\%$, 1/4 W Resistor	110000-820
R100-R102	1 k Ω , $\pm 5\%$, 1/4 W Resistor	110000-102
R103	4.7 k Ω , $\pm 5\%$, 1/4 W Resistor	110000-472
R104	10 k Ω , $\pm 5\%$, 1/4 W Resistor	110000-103
R105	22 k Ω , $\pm 5\%$, 1/4 W Resistor	110000-223
R106	15 k Ω , $\pm 5\%$, 1/4 W Resistor	110000-153
R107	1 k Ω , $\pm 5\%$, 1/4 W Resistor	110000-102
R108	82 Ω , $\pm 5\%$, 1/4 W Resistor	110000-820
R109	100 Ω , $\pm 5\%$, 1/4 W Resistor	110000-101
R110-R112	1 k Ω , $\pm 5\%$, 1/4 W Resistor	110000-102
R113	4.7 k Ω , $\pm 5\%$, 1/4 W Resistor	110000-472
R114	10 k Ω , $\pm 5\%$, 1/4 W Resistor	110000-103
R115	22 k Ω , $\pm 5\%$, 1/4 W Resistor	110000-223
R116	15 k Ω , $\pm 5\%$, 1/4 W Resistor	110000-153
R117	1 k Ω , $\pm 5\%$, 1/4 W Resistor	110000-102
R118	100 Ω , $\pm 5\%$, 1/4 W Resistor	110000-101
R119	82 Ω , $\pm 5\%$, 1/4 W Resistor	110000-820
R120-R122	1 k Ω , $\pm 5\%$, 1/4 W Resistor	110000-102
R123	4.7 k Ω , $\pm 5\%$, 1/4 W Resistor	110000-472
R124	10 k Ω , $\pm 5\%$, 1/4 W Resistor	110000-103
R125	22 k Ω , $\pm 5\%$, 1/4 W Resistor	110000-223
R126	15 k Ω , $\pm 5\%$, 1/4 W Resistor	110000-153
R127	1 k Ω , $\pm 5\%$, 1/4 W Resistor	110000-102
R128	82 Ω , $\pm 5\%$, 1/4 W Resistor	110000-820
R129	100 Ω , $\pm 5\%$, 1/4 W Resistor	110000-101
R130	150 Ω , $\pm 5\%$, 1/4 W Resistor	110000-151
R131-R140	1 k Ω , $\pm 5\%$, 1/4 W Resistor	110000-102
Sockets		
1A	28-Contact, Medium-Insertion-Force IC Socket	79-42C28
1C	28-Contact, Medium-Insertion-Force IC Socket	79-42C28
1D	28-Contact, Medium-Insertion-Force IC Socket	79-42C28
1F	28-Contact, Medium-Insertion-Force IC Socket	79-42C28
1H/J	28-Contact, Medium-Insertion-Force IC Socket	79-42C28
1K	28-Contact, Medium-Insertion-Force IC Socket	79-42C28
1T	28-Contact, Medium-Insertion-Force IC Socket	79-42C28
1M	28-Contact, Medium-Insertion-Force IC Socket	79-42C28

(continued on next page)

Main PCB Assembly Parts List, continued

Designator	Description	Part No.
3/4A	40-Contact, Medium-Insertion-Force IC Socket	79-42C40
3/4C	40-Contact, Medium-Insertion-Force IC Socket	79-42C40
5D	28-Contact, Medium-Insertion-Force IC Socket	79-42C28
6N	28-Contact, Medium-Insertion-Force IC Socket	79-42C28
6R	28-Contact, Medium-Insertion-Force IC Socket	79-42C28
10A/C	40-Contact, Medium-Insertion-Force IC Socket	79-42C40
10S/T	28-Contact, Medium-Insertion-Force IC Socket	79-42C28
12B	18-Contact, Medium-Insertion-Force IC Socket	79-42C18
12C	18-Contact, Medium-Insertion-Force IC Socket	79-42C18
13A	28-Contact, Medium-Insertion-Force IC Socket	79-42C28
13B/C	28-Contact, Medium-Insertion-Force IC Socket	79-42C28
13D	28-Contact, Medium-Insertion-Force IC Socket	79-42C28
13F	28-Contact, Medium-Insertion-Force IC Socket	79-42C28
14F	28-Contact, Medium-Insertion-Force IC Socket	79-42C28
Miscellaneous		
Q3	Nylon Snap-in Fastener	81-4302
Q4	Nylon Snap-in Fastener (Acceptable substitute is part no. 020670-01)	81-4302
Y1	10.000 MHz Crystal	90-123
Y2	12.096 MHz Crystal	144000-001

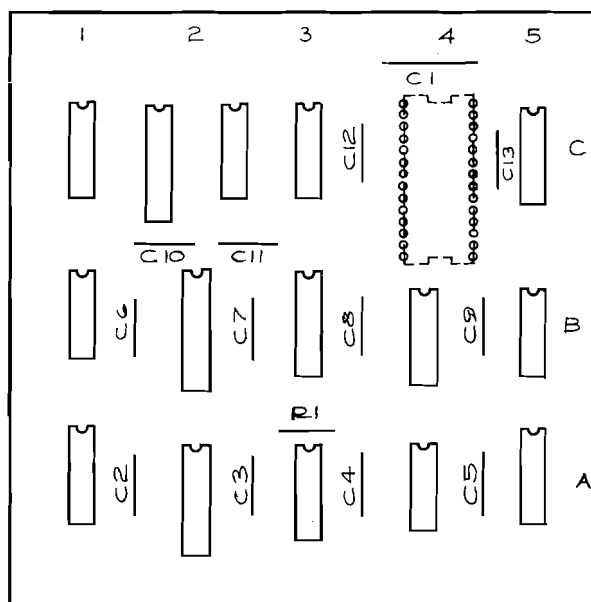

**Figure 5-11 PIXII II Printed-Circuit Board Assembly
A042686-01 A
Parts List**

Designator	Description	Part No.
Capacitors		
C1	22 μ F, 25 V, Electrolytic Capacitor	24-250226
C2-C13	0.1 μ F, 25 V, Ceramic Capacitor	122006-104
Integrated Circuits		
1A	Type-74LS163A Integrated Circuit	37-74LS163A
1B	Type-74LS125 Integrated Circuit	137317-001
1C	Type-74S157 Integrated Circuit	37-74S157
1/2C	Type-74S374 Integrated Circuit	137206-001
2B	Type-74S374 Integrated Circuit	137206-001
2/3C	Type-74LS174 Integrated Circuit	37-74LS174
3A	Type-74LS163A Integrated Circuit	37-74LS163A
4A	Type-74LS30 Integrated Circuit	37-74LS30
4B	Type-74LS174 Integrated Circuit	37-74LS174
5A	Type-74LS163A Integrated Circuit	37-74LS163A
5B	Type-74S02 Integrated Circuit	37-74S02
5C	Type-74LS174 Integrated Circuit	37-74LS174
Programmable Read-Only Memories & Random-Access Memory		
2A	Type-2149H-3 RAM Integrated Circuit	
3B	Type-82S137 PROM Integrated Circuit	136030-118
3C	Type-137336-025 PROM Integrated Circuit	136030-117
Resistor		
R1	1 k Ω , \pm 5%, $\frac{1}{4}$ W Resistor	110000-102
Miscellaneous		
	Socket Terminal Carrier Assembly	179175-028

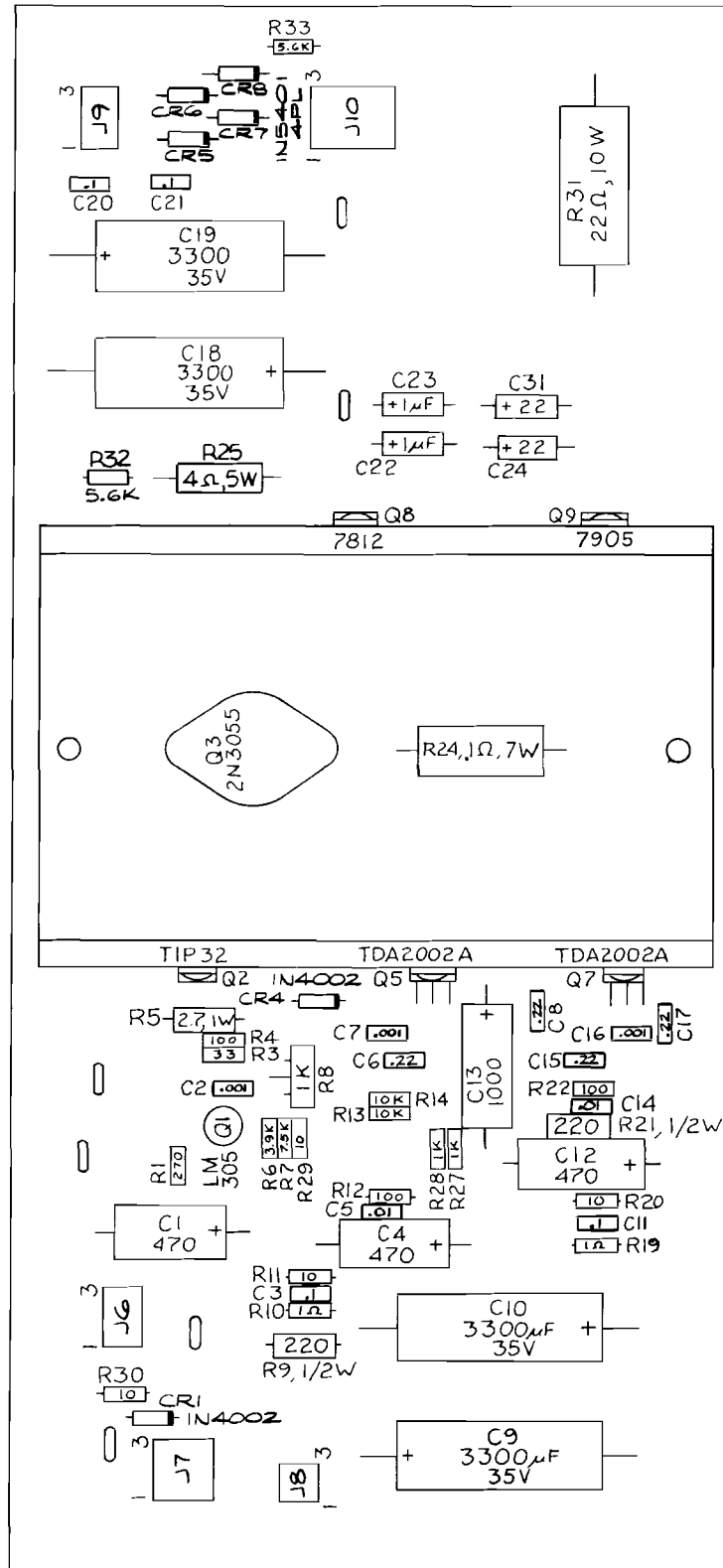

Figure 5-12 Regulator/Audio II PCB Assembly
A035435-02 K

Regulator/Audio II PCB Assembly Parts List

Designator	Description	Part No.
Capacitors		
C1	470 μ F, 25 V, Aluminum Electrolytic Fixed Axial-Lead Capacitor	24-250477
C2	0.001 μ F, 50 V, Ceramic-Disc Axial-Lead Capacitor	122002-102
C3	0.1 μ F, 50 V, Ceramic-Disc Axial-Lead Capacitor (Acceptable substitute is part no. 122002-104)	29-088
C4	470 μ F, 25 V, Aluminum Electrolytic Fixed Axial-Lead Capacitor	24-250477
C5	0.01 μ F, 25 V Minimum, Ceramic-Disc Axial-Lead Capacitor (Acceptable substitute is part no. 122005-103)	100015-103
C6	0.22 μ F, 25 V, Ceramic-Disc Axial-Lead Capacitor	122004-224
C7	0.001 μ F, 50 V, Ceramic-Disc Axial-Lead Capacitor	122002-102
C8	0.22 μ F, 25 V, Ceramic-Disc Axial-Lead Capacitor	122004-224
C9, C10	3300 μ F, 35 V, Aluminum Electrolytic Fixed Axial-Lead Capacitor	24-350338
C11	0.1 μ F, 50 V, Ceramic-Disc Axial-Lead Capacitor (Acceptable substitute is part no. 122002-104)	29-088
C12	470 μ F, 25 V, Aluminum Electrolytic Fixed Axial-Lead Capacitor	24-250477
C13	1000 μ F, 25 V, Aluminum Electrolytic Fixed Axial-Lead Capacitor	24-250108
C14	0.01 μ F, 25 V Minimum, Ceramic-Disc Axial-Lead Capacitor (Acceptable substitute is part no. 122005-103)	100015-103
C15	0.22 μ F, 25 V, Ceramic-Disc Axial-Lead Capacitor	122004-224
C16	0.001 μ F, 50 V, Ceramic-Disc Axial-Lead Capacitor	122002-102
C17	0.22 μ F, 25 V, Ceramic-Disc Axial-Lead Capacitor	122004-224
C18, C19	3300 μ F, 35 V, Aluminum Electrolytic Fixed Axial-Lead Capacitor	24-350338
C20, C21	0.1 μ F, 50 V, Ceramic-Disc Axial-Lead Capacitor (Acceptable substitute is part no. 122002-104)	29-088
C22, C23	1 μ F, 50 V, Aluminum Electrolytic Fixed Axial-Lead Capacitor	24-500105
C24	22 μ F, 35 V, Aluminum Electrolytic Fixed Axial-Lead Capacitor	24-350226
C31	22 μ F, 35 V, Aluminum Electrolytic Fixed Axial-Lead Capacitor	24-350226
Diodes		
CR1	Type-1N4002, 1 A, 100 V Silicon Rectifier Diode	31-1N4002
CR4	Type-1N4002, 1 A, 100 V Silicon Rectifier Diode	31-1N4002
CR5-CR8	Type-1N5401, 3 A, 100 V Silicon Rectifier Diode	31-1N5401
Resistors		
R1	270 Ω , $\pm 5\%$, $\frac{1}{4}$ W Resistor	110000-271
R3	33 Ω , $\pm 5\%$, $\frac{1}{4}$ W Resistor	110000-330
R4	100 Ω , $\pm 5\%$, $\frac{1}{4}$ W Resistor	110000-101
R5	2.7 Ω , $\pm 5\%$, 1 W Resistor	110009-027
R6	3.9 k Ω , $\pm 5\%$, $\frac{1}{4}$ W Resistor	110000-392
R7	7.5 k Ω , $\pm 5\%$, $\frac{1}{4}$ W Resistor	110000-752
R8	1 k Ω Vertical PCB-Mounting Cermet Potentiometer	119002-102
R9	220 Ω , $\pm 5\%$, $\frac{1}{2}$ W Resistor	110001-221
R10	1 Ω , $\pm 5\%$, $\frac{1}{4}$ W Resistor	110000-010
R11	10 Ω , $\pm 5\%$, $\frac{1}{4}$ W Resistor	110000-100
R12	100 Ω , $\pm 5\%$, $\frac{1}{4}$ W Resistor	110000-101
R13, R14	10 k Ω , $\pm 5\%$, $\frac{1}{4}$ W Resistor	110000-103

(continued on next page)

Regulator/Audio II PCB Assembly Parts List, continued

Designator	Description	Part No.
R19	1 Ω , $\pm 5\%$, $\frac{1}{4}$ W Resistor	110000-010
R20	10 Ω , $\pm 5\%$, $\frac{1}{4}$ W Resistor	110000-100
R21	220 Ω , $\pm 5\%$, $\frac{1}{2}$ W Resistor	110001-221
R22	100 Ω , $\pm 5\%$, $\frac{1}{4}$ W Resistor	110000-101
R24	0.1 Ω , $\pm 3\%$, 7 W Wirewound Resistor	19-100P1015
R25	4 Ω , $\pm 5\%$, 5 W Wirewound Resistor	116001-040
R27, R28	1 k Ω , $\pm 5\%$, $\frac{1}{4}$ W Resistor	110000-102
R29, R30	10 Ω , $\pm 5\%$, $\frac{1}{4}$ W Resistor	110000-100
R31	22 Ω , $\pm 5\%$, 10 W Wirewound Resistor	116000-220
R32, R33	5.6 k Ω , $\pm 5\%$, $\frac{1}{4}$ W Resistor	110000-562
Transistors		
Q2	Type-TIP32 PNP Power Transistor	33-TIP32
Q3	Type-2N3055 NPN Silicon Transistor	34-2N3055
Miscellaneous		
J6	6-Position Connector Receptacle	79-58306
J7	9-Position Connector Receptacle	79-58308
J8	4-Position Connector Receptacle	79-58354
J9	6-Position Connector Receptacle	79-58306
J10	12-Position Connector Receptacle	79-58346
Q1	Type-LM305, 5 V, Linear Voltage Regulator	37-LM305
Q2, Q9	Thermally Conductive Silicon Insulator	78-16014
Q3	Thermally Conductive Silicon Insulator	78-16008
Q5	Type-TDA2002A Linear Audio Amplifier	137151-002
Q7	Type-TDA2002A Linear Audio Amplifier	137151-002
Q8	Type-7812, +12 V, Voltage Regulator	37-7812
Q9	Type-7905, -5 V, Voltage Regulator	37-7905
	Heat Sink	034531-01
	Test Point (Acceptable substitute is part no. 179051-001)	179051-002

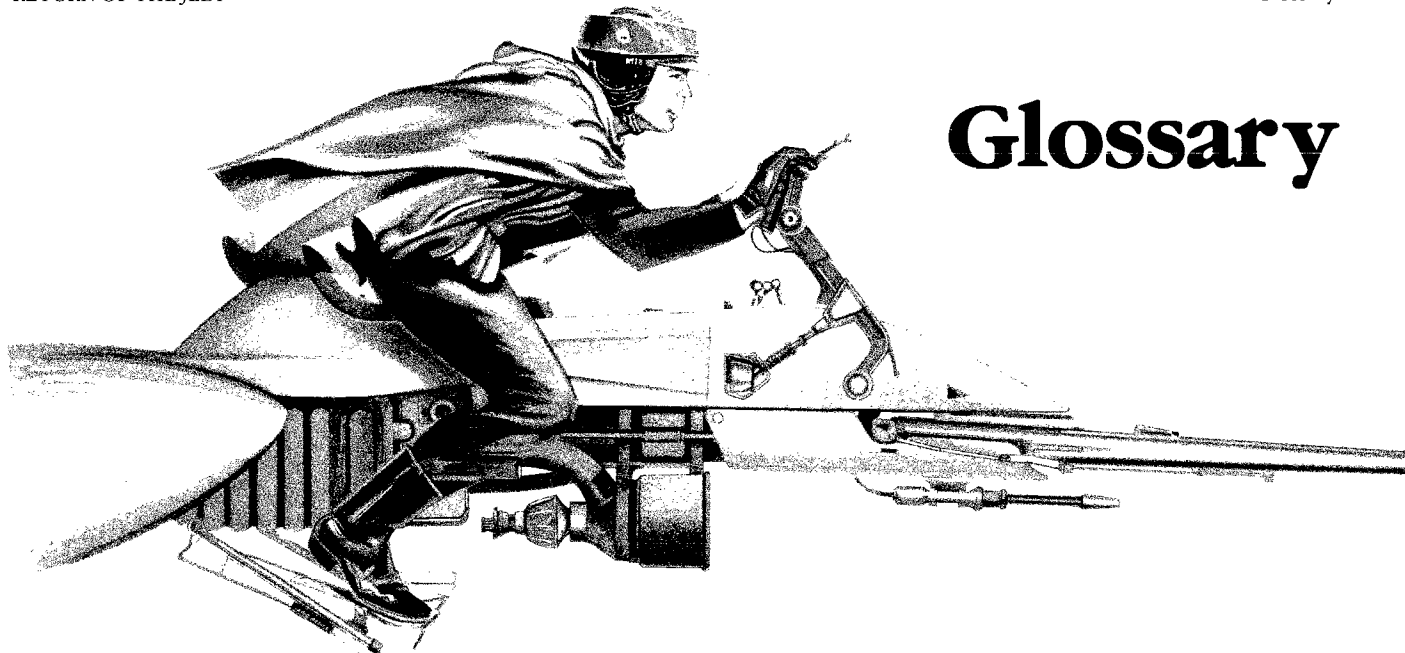

Glossary

AC

Alternating current; from zero it rises to a maximum positive level, then passes through zero again to a maximum negative level.

ACTIVE STATE

The true state of a signal. For example: The active state for START is low.

ADDRESS

A value that identifies a specific location of data in memory; normally expressed in hexadecimal notation.

ANALOG

Measurable in an absolute quantity (as opposed to on or off). Analog devices are volume controls, light dimmers, stereo amplifiers, etc.

ANODE

The positive (arrow) end of a diode.

AMPLIFIER

A device used to increase the strength of an applied signal.

AMPLITUDE

The maximum instantaneous value of a waveform pulse from zero.

ASTABLE

Having no normal state. An astable device will free-run or oscillate as long as operating voltage is applied. The oscillation frequency is usually controlled by external circuitry.

AUXILIARY COIN SWITCH

A momentary-contact pushbutton switch with a black cap located on the utility panel. The auxiliary coin switch adds credits to the game without activating the coin counter.

BEZEL

A cut, formed, or machined retention device, such as the conical device used to mount a pushbutton switch to a control panel, or the formed device used to frame the video display screen.

BIDIRECTIONAL

Able to send or receive data on the same line (e.g., the data bus of a microprocessor).

BINARY

A number system that expresses all values by using two digits (0 and 1).

BIT

A binary digit; expressed as a 1 or a 0.

BLANKING

Turning off the beam on a cathode-ray tube during retrace.

BLOCK DIAGRAM

A drawing in which functional circuitry units are represented by blocks. Very useful during initial troubleshooting.

BUFFER

1. An isolating circuit designed to eliminate the reaction of a driven circuit on the circuits driving it (e.g., a buffer amplifier).

2. A device used to supply additional drive capability.

BUS

An electrical path over which information is transferred from any of several sources to any of several destinations.

CAPACITOR

A device capable of storing electrical energy. A capacitor blocks the flow of DC current while allowing AC current to pass.

CATHODE

The negative end of a diode.

CHIP

An integrated circuit comprising many circuits on a single wafer slice.

CLOCK

A repetitive timing signal for synchronizing system functions.

COINCIDENCE

Occurring at the same time.

COIN COUNTER

A 6-digit electro-mechanical device that counts the coins inserted in the coin mechanism(s).

COIN MECHANISM

A device on the inside of the coin door that inspects the coin to determine if the correct coin has been inserted.

COMPLEMENTARY

Having opposite states, such as the outputs of a flip-flop.

COMPOSITE SYNC

Horizontal and vertical synchronization pulses that are bused together into a single signal. This signal provides the timing necessary to keep the display in synchronization with the game circuitry.

COMPOSITE VIDEO

Complete video signal from the game system to drive the display circuitry, usually comprising H SYNC, V SYNC, and the video.

CREDIT

One play for one person based on the game switch settings.

CRT

Cathode-ray tube.

DATA

General term for the numbers, letters, and symbols that serve as input for device processing.

DARLINGTON

A two-transistor amplifier that provides extremely high gain.

DC

Direct current, meaning current flowing in one direction and of a fixed value.

DEFLECTION YOKE

Electro-magnetic coils around the neck of a cathode-ray tube. One set of coils deflects the electron beam horizontally and the other set deflects the beam vertically.

DIAGNOSTICS

A programmed routine for checking circuitry. For example: the self-test is a diagnostic routine.

DIODE

A semiconductor device that conducts in only one direction.

DISCRETE

Non-integrated components, such as resistors, capacitors, and transistors.

DMA

Direct memory access. DMA is a process of accessing memory that bypasses the microprocessor logic. DMA is normally used for transferring data between the input/output ports and memory.

DOWN TIME

The period during which a game is malfunctioning or not operating correctly due to machine failure.

EAROM

Electrically alterable read-only memory (see ROM). The EAROM is a memory that can be changed by the application of high voltage.

FLYBACK

A step-up transformer used in a display to provide the high voltage.

GATE

1. A circuit with one output that responds when and only when a certain combination of pulses is present at the inputs.

2. A circuit in which one signal switches another signal on and off.

3. To control the passage of a pulse or signal.

HARNESS

A prefabricated assembly of insulated wires and terminals ready to be attached to a piece of equipment.

HEXADECIMAL

A number system using the equivalent of the decimal number 16 as a base. The symbols 0-9 and A-F are usually used.

IMPLODE

To burst inward; the inward collapse of a vacuum tube.

I/O

Input/Output.

IRQ

Interrupt request. IRQ is a control signal to the microprocessor that is generated by external logic. This signal tells the microprocessor that external logic needs attention. Depending on the program, the processor may or may not respond.

LED

The abbreviation for a light-emitting diode.

LOCKOUT COIL

Directs coins into the coin return box when there is no power to the game.

LOGIC STATE

The binary (1 or 0) value at the node of a logic element or integrated circuit during a particular time. Also called the logic level. The list below shows the voltage levels corresponding to the logic states (levels) in a TTL system.

Logic 0, Low = 0 VDC to +0.8 VDC

Grey Area (Tri-State Level) =

+0.8 VDC to +2.4 VDC

Logic 1, High =

+2.4 VDC to +5 VDC

MULTIPLEXER

A device that takes several low-speed inputs and combines them into one high-speed data stream for simultaneous transmission on a single line.

NMI

Non-maskable interrupt. NMI is a request for service by the microprocessor from external logic. The microprocessor cannot ignore this interrupt request.

PAGE

A subsection of memory. A read-only memory device (see ROM) is broken into discrete blocks of data. These blocks are called pages. Each block has X number of bytes.

PCB

The abbreviation for a printed-circuit board.

PHOTOTRANSISTOR

A transistor that is activated by an external light source.

POTENTIOMETER

1. A resistor that has a continuously moving contact which is generally mounted on a moving shaft. Used chiefly as a voltage divider. Also called a *pot* (slang).

2. An instrument for measuring a voltage by balancing it against a known voltage.

RAM

Random-access memory. A device for the temporary storage of data.

RASTER-SCAN DISPLAY

A display system whereby images are displayed by continuously scanning the cathode-ray tube horizontally and vertically with an electron beam. The display system controls the intensity of the electron beam.

RETRACE

In a raster-scan display, retrace is the time during which the cathode-ray tube electron beam is resetting either from right to left or from bottom to top.

RESISTOR

A device designed to have a definite amount of resistance. Used in circuits to limit current flow or to provide a voltage drop.

ROM

Read-only memory. A device for the permanent storage of data.

SIGNATURE ANALYSIS

A process of isolating digital logic faults at the component level by means of special test equipment called signature analyzers. Basically, signature analyzers (e.g., the ATARI® CAT Box) convert lengthy bit streams into four-digit hexadecimal signatures. The signature read by the analyzer at each circuit node is then compared with the known good signature for that node. This process continues until a fault is located.

TROUBLESHOOT

The process of locating and repairing a fault.

VECTOR

A line segment drawn between specific X and Y coordinates on a cathode-ray tube.

WATCHDOG

A counter circuit designed to protect the microprocessor from self-destruction if a program malfunction occurs. If a malfunction does occur, the counter applies continuous pulses to the reset line of the microprocessor, which causes the microprocessor to keep resetting.

X-Y DISPLAY

A display system whereby images are displayed with vectors.

ZENER DIODE

A special diode used as a regulator. Its main characteristic is breaking down at a specified reverse-bias (Zener) voltage.

YOUR COMMENTS, PLEASE!

Your comments will assist Atari in improving our publications. The comments are an important part of preparing for revisions of game manuals. Please write in the space below. No postage stamp is necessary if mailed in the U.S.A.

If you have any technical questions about certain ATARI games products, or are requesting additional publications, we will immediately forward your note to the appropriate person.

Page: Comments:

Fill in if you wish a reply:

Name _____

Firm _____

Address _____

City _____ State _____ Zip _____

Area Code _____ Phone _____

Distributor

Operator

Other _____

First Fold



No postage
necessary if
mailed in the
United States

BUSINESS REPLY MAIL

FIRST CLASS PERMIT NO. 173 MILPITAS, CA

POSTAGE WILL BE PAID BY ADDRESSEE

Atari Inc.
Attn: Customer Service/Coin-Op Division
737 Sycamore Drive
P.O. Box 906
Milpitas, California 95035

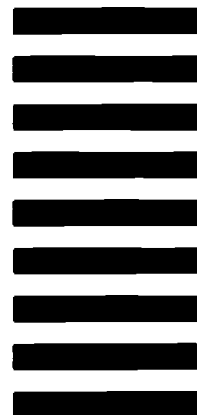

Second Fold

From:

Tape This Edge

YOUR COMMENTS, PLEASE!

Your comments will assist Atari in improving our publications. The comments are an important part of preparing for revisions of game manuals. Please write in the space below.

If you have any technical questions about certain ATARI games products, or are requesting additional publications, we will immediately forward your note to the appropriate person.

Page: Comments:

Fill in if you wish a reply:

Name _____

Firm _____

Address _____

City _____ Country _____

Phone: Country Code _____ Local Number _____

Distributor

Operator

Other _____

First Fold

Attach
Necessary
Postage

Atari Ireland Limited
Attn.: Field Service/Coin-Op Division
Tipperary Town, Ireland

Second Fold

From:

Tape this edge

A decorative border with a repeating floral pattern of stylized flowers and leaves, framing the central text.

Warranty

Seller warrants that its printed-circuit boards and parts thereon are free from defects in material and workmanship under normal use and service for a period of ninety (90) days from date of shipment. Seller warrants that its video displays (in games supplied with displays) are free from defects in material and workmanship under normal use and service for a period of thirty (30) days from date of shipment. None of the Seller's other products or parts thereof are warranted.

If the products described in this manual fail to conform to this warranty, Seller's sole liability shall be, at its option, to repair, replace, or credit Buyer's account for such products which are returned to Seller during said warranty period, provided:

- (a) Seller is promptly notified in writing upon discovery by Buyer that said products are defective;
- (b) Such products are returned prepaid to Seller's plant; and
- (c) Seller's examination of said products discloses to Seller's satisfaction that such alleged defects existed and were not caused by accident, misuse, neglect, alteration, improper repair, installation, or improper testing.

In no event shall Seller be liable for loss of profits, loss of use, incidental or consequential damages.

Except for any express warranty set forth in a written contract between Seller and Buyer which contract supersedes the terms herein, this warranty is expressed in lieu of all other warranties expressed or implied, including the implied warranties of merchantability and fitness for a particular purpose, and of all other obligations or liabilities on the Seller's part, and it neither assumes nor authorizes any other person to assume for the Seller any other liabilities in connection with the sale of products by Seller.

The use of any non-Atari parts may void your warranty, according to the terms of the warranty. The use of any non-Atari parts may also adversely affect the safety of your game and cause injury to you and others. Be very cautious in using non-Atari-supplied components with our games, in order to insure your safety.

Atari distributors are independent, being privately owned and operated. In their judgment they may sell parts or accessories other than Atari parts or accessories. Atari cannot be responsible for the quality, suitability or safety of any non-Atari part or any modification including labor which is performed by such distributor.



 A Warner Communications Company

ATARI, INC.
1501 MCCARTHY BLVD.
P.O. BOX 906
MILPITAS, CALIFORNIA 95035
408/942-3100 • TELEX 35-7488

© 1984 Lucasfilm Ltd. & Atari, Inc. All rights reserved.
*Trademarks of Lucasfilm Ltd. used by Atari, Inc. under license.

